



E-Series Systems

E2600 Controller-Drive Tray and Related Drive Trays Installation Guide

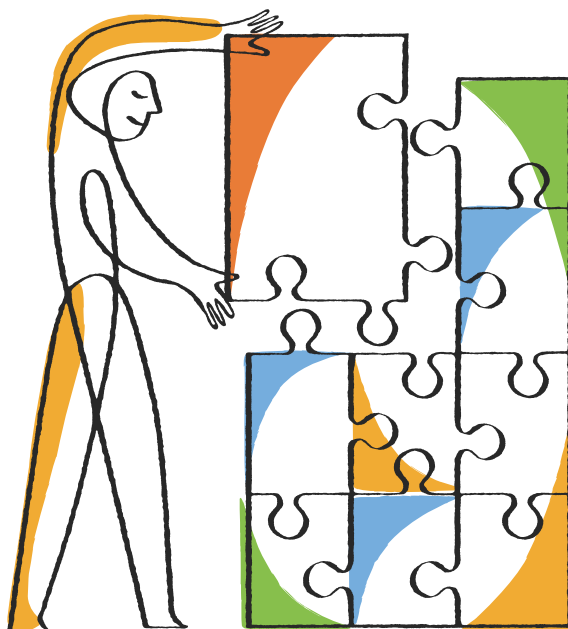


Table of Contents

Deciding Whether to Use this Guide	1
How to send your comments	2
Step 1 – Preparing for an E2600 Controller-Drive Tray Installation	3
Key Terms.....	5
Gathering Items.....	6
Basic Hardware.....	7
E2600 Configuration Cables and Connectors.....	8
Tools and Other Items.....	9
Things to Know – SFP Transceivers, Fiber-Optic Cables, Copper Cables, and SAS Cables.....	10
Things to Know –Taking a Quick Glance at the Hardware in an E2612 Controller-Drive Tray or an E2624 Controller-Drive Tray Configuration.....	12
Things to Know – Taking a Quick Glance at the Hardware in a E2660 Controller-Drive Tray Configuration.....	19
For Additional Information on the E2600 Controller-Drive Tray Configuration.....	26
Step 2 – Installing and Configuring the Switches	27
Things to Know –Switches, Routers, and SFPs.....	27
Procedure – Installing and Configuring Switches.....	29
Step 3 – Installing the Host Bus Adapters for the E2600 Controller-Drive Tray	30
Key Terms.....	30
Things to Know – Host Bus Adapters and Ethernet Network Interface Cards.....	30
Procedure – Installing Fibre Channel Host Bus Adapters.....	30
Step 4 – Installing the E2600 Controller-Drive Tray	32
Things to Know – General Installation.....	32
Procedure – Installing the E2612 Controller-Drive Tray or the E2624 Controller-Drive Tray.....	32
Procedure – Installing the E2660 Controller-Drive Tray.....	40
Steps to Install – Drives on the E2660 Controller-Drive Tray.....	49
Step 5 – Connecting the E2600 Controller-Drive Tray to the Hosts	53
Key Terms.....	53
Things to Know – Storage Array Configuration Specifications for the E2600 Controller-Drive Tray.....	53
Things to Know – Host Channels.....	54
Procedure – Connecting Host Cables on a E2600 Controller-Drive Tray.....	56
Step 6 – Installing the Drive Trays for the E2600 Controller-Drive Tray Configurations	63
Things to Know – General Installation of Drive Trays with the E2600 Controller-Drive Tray.....	63
Procedure – Installing the DE1600 Drive Trays and the DE5600 Drive Trays.....	63
Procedure – Installing Drives in the DE1600 Drive Trays and the DE5600 Drive Trays.....	70
Things to Know – General Installation of Drive Trays with the E2660 Controller-Drive Tray.....	72
Procedure – Installing the DE6600 Drive Tray.....	72
Procedure – Installing Drives in the DE6600 Drive Tray.....	81
Procedure – Connecting the Power Cords.....	84

Things to Know – Connecting the Power Cords.....	84
Step 7 – Connecting the E2600 Controller-Drive Tray to the Drive Trays.....	85
Key Terms.....	85
Things to Know – E2600 Controller-Drive Tray.....	85
Things to Know – Drive Trays with the E2612 or the E2624 Controller-Drive Tray.....	86
Things to Know – Drive Tray Cabling Configurations – Simplex System.....	87
Things to Know – Drive Tray Cabling Configurations – Duplex System.....	88
Procedure –Connecting the DE1600 Drive Trays and the DE5600 Drive Trays.....	90
Things to Know – E2660 Controller-Drive Tray.....	92
Things to Know – Drive Trays with the E2660 Controller-Drive Tray.....	93
Things to Know – E2660 Drive Tray Cabling Configurations – Duplex System.....	93
Procedure – Connecting the DE6600 Drive Tray.....	94
Step 8 – Connecting the Ethernet Cables.....	96
Key Terms.....	96
Things to Know – Connecting Ethernet Cables.....	96
Procedure – Connecting Ethernet Cables.....	96
Step 9 – Connecting the Power Cords.....	97
Things to Know – AC Power Cords.....	97
Procedure – Connecting AC Power Cords.....	97
Step 10 – Turning on the Power and Checking for Problems in a E2600 Controller-Drive Tray Configuration.....	98
Procedure – Turning On the Power to the Storage Array and Checking for Problems in a E2600 Controller-Drive Tray Configuration.....	98
Things to Know – LEDs on the E2600 Controller-Drive Tray.....	98
Things to Know – LEDs on the E2660 Controller-Drive Tray.....	105
Things to Know – General Behavior of the LEDs on the Controller-Drive Tray.....	110
Things to Know – Service Action Allowed LEDs.....	112
Things to Know – LEDs on the DE1600 Drive Tray and the DE5600 Drive Tray.....	113
Things to Know – LEDs on the DE6600 Drive Tray.....	117
LEDs on the DE6600 Drive Drawers.....	121
Things to Know - LEDs on the DE6600 Drives.....	122
Things to Know - General Behavior of the LEDs on the Drive Trays.....	123
Things to Know –Seven Segment Component Failure Identifications for the E2600 Controller-Drive Tray.....	124
Things to Know – Seven Segment Display Sequence Code Definitions on the E2600 Controller-Drive Tray.....	125
Things to Know – Lock-Down Codes for the Controller-Drive Tray.....	126
Things to Know – Seven-Segment Display Use Cases.....	127
Things to Know – Seven-Segment Display for the ESMs on the Drive Trays.....	128
Regulatory Compliance Statements.....	130
Trademark information.....	132
Copyright information.....	133

Deciding Whether to Use this Guide

This guide is intended for hardware installers and system administrators who are installing an E2600 controller-drive tray and the related drive trays into a storage array. Use this guide if you want to accomplish these goals:

- Install, rack, and cable the E2600 controller-drive tray and the related drive trays.
- This guide does not provide extensive conceptual background or information about how to install and configure the SANtricity® Storage Manager software. Refer to the appropriate Express Guide or to the *Software Installation Reference* for SANtricity Storage Manager 11.20 to learn how to install and configure the storage management software.

This guide is based on the following assumptions:

- You have consulted the *Site Preparation Guide* to plan the installation of this hardware in a cabinet.
- You have all the necessary hardware required to install the controller-drive tray and drive trays for the storage array.

Where to Find the Latest Information About the Product

You can find information about the latest version of the product, including new features and fixed issues, and a link to the latest documentation at the following address: mysupport.netapp.com/eseries.

How to send your comments

You can help us to improve the quality of our documentation by sending us your feedback.

Your feedback is important in helping us to provide the most accurate and high-quality information. If you have suggestions for improving this document, send us your comments by email to doccomments@netapp.com. To help us direct your comments to the correct division, include in the subject line the product name, version, and operating system.

You can also contact us in the following ways:

- NetApp, Inc., 495 East Java Drive, Sunnyvale, CA 94089 U.S.
- Telephone: +1 (408) 822-6000
- Fax: +1 (408) 822-4501
- Support telephone: +1 (888) 463-8277

Step 1 – Preparing for an E2600 Controller-Drive Tray Installation

Storage arrays for 6-Gb/s SAS drives consist of a E2600 controller-drive tray model and one or more drive trays in a cabinet.

Use this document to install one of the following E2600 controller-drive tray models and all necessary drive trays for your configuration:

- E2612 controller-drive tray
- E2624 controller-drive tray
- E2660 controller-drive tray

The following tables show the various configuration options.

Table 1. E2612 Controller-Drive Tray and E2624 Controller-Drive Tray Options

E2600 Configurations	Options
Simplex (one controller) E2612 controller-drive tray or E2624 controller-drive tray with no host interface card	<p>A maximum of 192 drives.</p> <p>Any combination of E2600 controller-drive trays attached to DE1600 drive trays or DE5600 drive trays, or DE6600 drive trays not to exceed a maximum of 192 drive slots or 16 total trays in the storage array.</p> <p>Two 6-Gb/s SAS host connectors.</p> <p>Options of 1-GB, 2-GB, or 4-GB memory for cache offload to flash memory battery backup.</p>
Simplex E2612 controller-drive tray or E2624 controller-drive tray with a host interface card	<p>A maximum of 192 drives.</p> <p>Any combination of E2600 controller-drive trays attached to DE1600 drive trays, DE5600 drive trays, or DE6600 drive trays not to exceed a maximum of 192 drive slots or 16 total trays in the storage array.</p> <p>Two 6-Gb/s SAS host connectors, in addition to one of the following host interface cards:</p> <ul style="list-style-type: none"> ■ Two 6-Gb/s SAS connectors ■ Four 1-Gb/s iSCSI connectors ■ Two 10-Gb/s iSCSI connectors ■ Four 8-Gb/s Fibre Channel (FC) connectors <p>Options of 1-GB, 2-GB, or 4-GB memory for cache offload to flash memory battery backup.</p>

E2600 Configurations	Options
<p>Duplex (two controllers) E2612 controller-drive tray or E2624 controller-drive tray without a host interface card</p>	<p>A maximum of 192 drives</p> <p>Any combination of E2600 controller-drive trays attached to DE1600 drive trays or DE5600 drive trays, or DE6600 drive trays not to exceed a maximum of 192 drive slots or 16 total trays in the storage array. You can intermix all three types of drive trays or have the following number of drive trays in a storage array:</p> <ul style="list-style-type: none"> ■ 15 DE1600 drive trays ■ 7 DE5600 drive trays ■ 3 DE6600 drive trays with a E2612 controller-drive tray ■ 2 DE6600 drive trays with a E2624 controller-drive tray <p>Two 6-Gb/s SAS host connectors.</p> <p>Options of 1-GB, 2-GB, or 4-GB memory for cache offload to flash memory battery backup.</p>
<p>Duplex E2612 controller-drive tray or E2624 controller-drive tray with a host interface card</p>	<p>A maximum of 192 drives</p> <p>Any combination of E2600 controller-drive trays attached to DE1600 drive trays or DE5600 drive trays, or DE6600 drive trays not to exceed a maximum of 192 drive slots or 16 total trays in the storage array. You can intermix all three types of drive trays, or have the following number of drive trays in a storage array:</p> <ul style="list-style-type: none"> ■ 15 DE1600 drive trays ■ 7 DE5600 drive trays ■ 3 DE6600 drive trays with a E2612 controller-drive tray ■ 2 DE6600 drive trays with a E2624 controller-drive tray <p>Two 6-Gb/s SAS host connectors, in addition to one of the following host interface cards:</p> <ul style="list-style-type: none"> ■ Two 6-Gb/s SAS connectors ■ Four 1-Gb/s iSCSI connectors ■ Two 10-Gb/s iSCSI connectors ■ Four 8-Gb/s FC connectors <p>Options of 1-GB, 2-GB, or 4-GB memory for cache offload to flash memory battery backup.</p>

Table 2. E2660 Controller-Drive Tray Options

E2660 Configurations	Options
<p>Duplex (two controllers) E2660 controller-drive tray without a host interface card</p>	<p>A maximum of 180 drives.</p> <p>Any combination of E2660 controller-drive trays attached to DE1600 drive trays, DE5600 drive trays, or DE6600 drive trays not to exceed a maximum of 192 drive slots or 16 total trays in the storage array. You can intermix all three types of drive trays, or have the following number of drive trays in a storage array:</p> <ul style="list-style-type: none"> ■ 11 DE1600 drive trays ■ 5 DE5600 drive trays ■ 2 DE6600 drive trays <p>Two 6-Gb/s SAS host connectors.</p> <p>Options of 1-GB, 2-GB, or 4-GB memory for cache offload to flash memory battery backup.</p>
<p>Duplex E2660 controller-drive tray with a host interface card</p>	<p>A maximum of 180 drives in the storage array.</p> <p>Any combination of E2660 controller-drive trays attached to DE1600 drive trays, DE5600 drive trays, or DE6600 drive trays not to exceed a maximum of 192 drive slots or 16 total trays in the storage array. You can intermix all three types of drive trays, or have the following number of drive trays in a storage array:</p> <ul style="list-style-type: none"> ■ 11 DE1600 drive trays ■ 5 DE5600 drive trays ■ 2 DE6600 drive trays <p>Two 6-Gb/s SAS host connectors, in addition to one of the following host interface cards:</p> <ul style="list-style-type: none"> ■ Two 6-Gb/s SAS connectors ■ Four 1-Gb/s iSCSI connectors ■ Two 10-Gb/s iSCSI connectors ■ Four 8-Gb/s FC connectors <p>Options of 1-GB, 2-GB, or 4-GB memory for cache offload to flash memory battery backup.</p>

ATTENTION Possible hardware damage – To prevent electrostatic discharge damage to the tray, use proper antistatic protection when handling tray components.

Key Terms

storage array

A collection of both physical components and logical components for storing data. Physical components include drives, controllers, fans, and power supplies. Logical components include disk pools, volume groups, and volumes. These components are managed by the storage management software.

controller-drive tray

One tray with drives, one or two controllers, fans, and power supplies. The controller-drive tray provides the interface between a host and a storage array.

controller

A circuit board and firmware that is located within a controller tray or a controller-drive tray. A controller manages the input/output (I/O) between the host system and data volumes.

drive tray

One tray with drives, one or two environmental services modules (ESMs), power supplies, and fans. A drive tray does not contain controllers.

environmental services module (ESM)

A canister in the drive tray that monitors the status of the components. An ESM also serves as the connection point to transfer data between the drive tray and the controller.

Small Form-factor Pluggable (SFP) transceiver

A component that enables Fibre Channel duplex communication between storage array devices. SFP transceivers can be inserted into host bus adapters (HBAs), controllers, and environmental services modules (ESMs). SFP transceivers can support either copper cables (the SFP transceiver is integrated with the cable) or fiber-optic cables (the SFP transceiver is a separate component from the fiber-optic cable).

SFP transceivers also are supported and can be used for 10-Gb iSCSI protocol communication between the host and the storage array.

Gathering Items

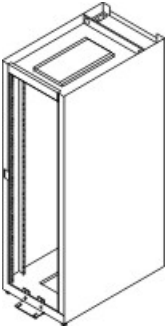

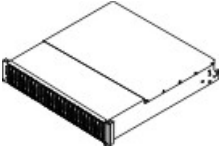


Before you start installing the controller-drive tray, you must have installed the cabinet in which the controller-drive tray will be mounted.

Use the tables in this section to verify that you have all of the necessary items to install the controller-drive tray.

ATTENTION Possible hardware damage – To prevent electrostatic discharge damage to the tray, use proper antistatic protection when handling tray components.

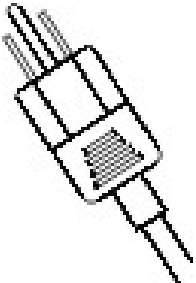

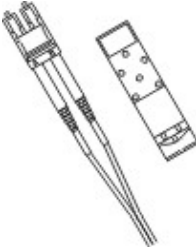


Basic Hardware

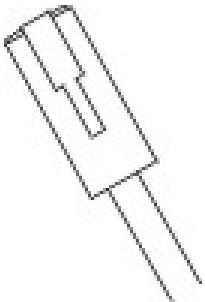
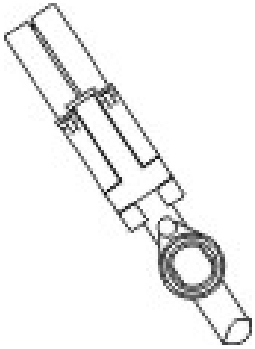


Table 3. Basic Hardware

	Item
	<p>Cabinet</p> <ul style="list-style-type: none"> ■ Make sure that your cabinet meets the installation site specifications of the various E2600 storage array components. Refer to the <i>Storage System Site Preparation Guide</i> for more information. ■ Depending on the power supply limitations of your cabinet, you might need to install more than one cabinet to accommodate the different components of the E2600 storage array. Refer to the installation guide for your cabinet for instructions on installing the cabinet.
	<p>DE1600 drive tray with end caps that are packaged separately. This drive tray can be used with all three variations of the E2600 controller-drive tray and ships with the drives installed.</p>
	<p>DE5600 drive tray with end caps that are packaged separately. This drive tray can be used with all three variations of the E2600 controller-drive tray and ships with the drives installed.</p>
	<p>DE6600 drive tray (shown with the separately packaged mounting rails attached). This drive tray can be used with all three variations of the E2600 controller-drive tray. The DE6600 drive tray ships without the drives so that they need to be installed when the drive tray is installed in the cabinet.</p>
	<p>Mounting rails and screws</p> <p>The mounting rails that are available with the drive tray are designed for an industry-standard cabinet.</p>
	<p>Fibre Channel switch (optional) SAS switch (optional)</p>
	<p>Gigabit Ethernet switch (optional)</p>
	<ul style="list-style-type: none"> ■ Host with Fibre Channel host bus adapters (HBAs) (optional) ■ Host with iSCSI HBAs (optional) or a network interface card (optional) ■ Host with SAS HBAs (optional)

E2600 Configuration Cables and Connectors

Table 4. Cables and Connectors


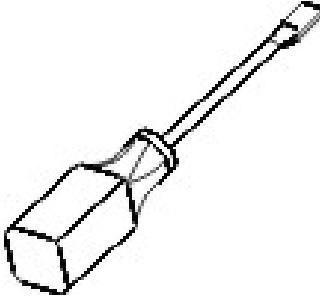

	Item	Included with the Controller-Drive Tray or Drive Trays
	<p>AC power cords.</p> <p>The controller-drive tray and the drive trays ship with power cords for connecting to an external power source, such as a wall plug. Your cabinet might have special power cords that you use instead of the power cords that ship with the controller-drive tray and the drive trays.</p>	
	<p>Copper SAS cables - Use for all drive-side connections within the storage array.</p> <p>Fiber-optic cables - Use for FC connections to the drive trays.</p> <p>For the differences between the fiber-optic cables and the copper Fibre Channel (FC) cables, see Things to Know – SFP Transceivers, Fiber-Optic Cables, Copper Cables, and SAS Cables on page 10.</p>	
	<p>Small Form-factor Pluggable (SFP) transceivers</p> <ul style="list-style-type: none"> ■ The SFP transceivers connect fiber-optic cables to host ports and drive ports. ■ Four or eight SFP transceivers are included with the controller-drive tray; one for each of the host channel ports on the controllers. ■ Depending on your connection requirements, you might need to purchase additional SFP transceivers (two SFP transceivers for each fiber-optic cable). ■ Depending on the configuration of your storage array, you might need to use 8-Gb/s Fibre Channel SFP transceivers. ■ You must purchase <i>only</i> Restriction of Hazardous Substances (RoHS)-compliant SFP transceivers. 	
	<p>Copper Fibre Channel cables (optional)</p> <p>Use these cables for connections within the storage array.</p> <p>For the differences between the fiber-optic cables and the copper Fibre Channel cables, see Things to Know – SFP Transceivers, Fiber-Optic Cables, Copper Cables, and SAS Cables on page 10.</p>	

	Item	Included with the Controller-Drive Tray or Drive Trays
	<p>Ethernet cable</p> <p>This cable is used for out-of-band storage array management and for 1-Gb/s iSCSI connections. For information about out-of-band storage array management, see the description for “Deciding on the Management Method” in <i>Software Installation Reference</i>.</p>	
	<p>SAS cables</p> <p>The SAS cables connect the host to the controller-drive tray. If you install a drive tray, you must use SAS cables to connect the controller-drive tray to the drive tray.</p>	
	<p>Serial cable</p> <p>This cable is used for support only. You do not need to connect it during initial installation.</p>	
	<p>DB9-to-PS2 adapter cable</p> <p>This cable adapts the DB9 connector on commercially available serial cables to the PS2 connector on the ESM for drive trays in the storage array. This cable is used for support only. You do not need to connect it during installation.</p>	

Tools and Other Items

Table 5. Tools and Other Items

	Item
	<p>Labels</p> <p>Help you to identify cable connections and lets you more easily trace cables from one tray to another</p>
	<p>A cart</p> <p>Holds the tray and components</p>
	<p>A mechanical lift (optional)</p>

	Item
	A Phillips screwdriver
	A flat-blade screwdriver
	Anti-static protection
	A flashlight

Things to Know – SFP Transceivers, Fiber-Optic Cables, Copper Cables, and SAS Cables

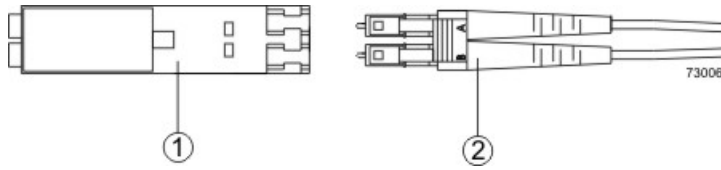
The figures in this topic show the fiber-optic cables, copper cables, SFP transceivers and SAS cables with a SFF-8088 Connector.

NOTE Your SFP transceivers and cables might look slightly different from the ones shown. The differences do not affect the performance of the SFP transceivers.

The controller-drive tray supports SAS, Fibre Channel (FC), and iSCSI host connections and SAS drive connections. FC host connections can operate at 8 Gb/s or at a lower data rate. Ports for 8-Gb/s Fibre Channel host connections require SFP transceivers designed for this data rate. These SFP transceivers look similar to other SFP transceivers but are not compatible with other types of connections. SFP transceivers for 1-Gb/s iSCSI and 10-Gb/s iSCSI connections have a different physical interface for the cable and are not compatible with other types of connections.

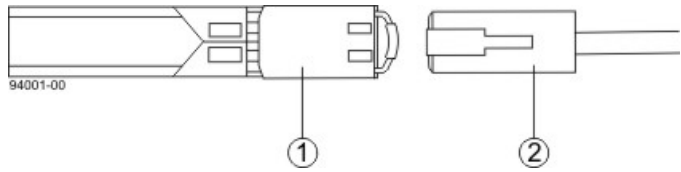
⚠ WARNING (W03) Risk of exposure to laser radiation – Do not disassemble or remove any part of a Small Form-factor Pluggable (SFP) transceiver because you might be exposed to laser radiation.

Figure 1. Fiber-Optic Cable Connection



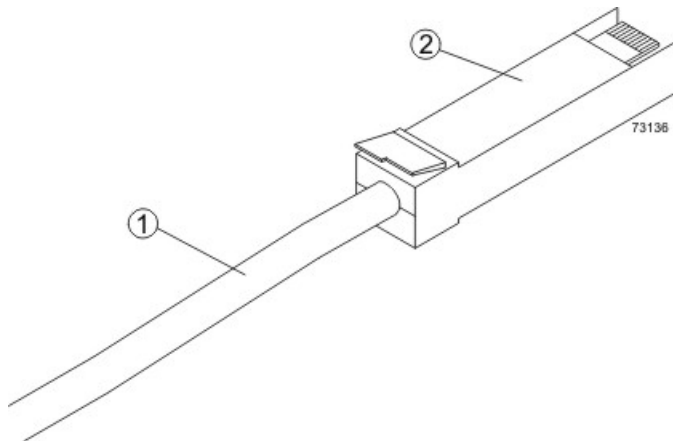
- 1. Active SFP Transceiver
- 2. Fiber-Optic Cable

Figure 2. 1-Gb/s iSCSI Cable Connection



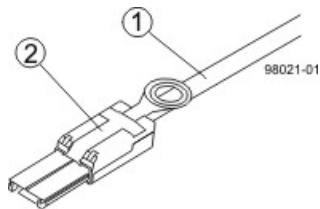
- 1. Active SFP Transceiver
- 2. Copper Cable with RJ-45 Connector

Figure 3. Copper Fibre Channel Cable Connection



- 1. Copper Fibre Channel Cable
- 2. Passive SFP Transceiver

Figure 4. SAS Cable Connection



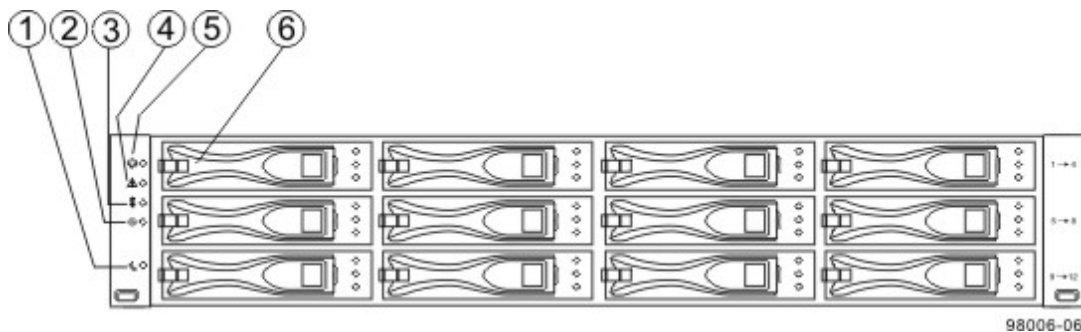
- 1. SAS Cable
- 2. SFF-8088 Connector

Things to Know –Taking a Quick Glance at the Hardware in an E2612 Controller-Drive Tray or an E2624 Controller-Drive Tray Configuration

- Each tray in the storage array must have a minimum of two drives for proper operation.
- iSCSI host ports do not support the Data Assurance (DA) premium feature.
- The top of the controller-drive tray is the side with labels.
- The configuration of the host ports might appear different on your system depending on which host interface card configuration is installed.

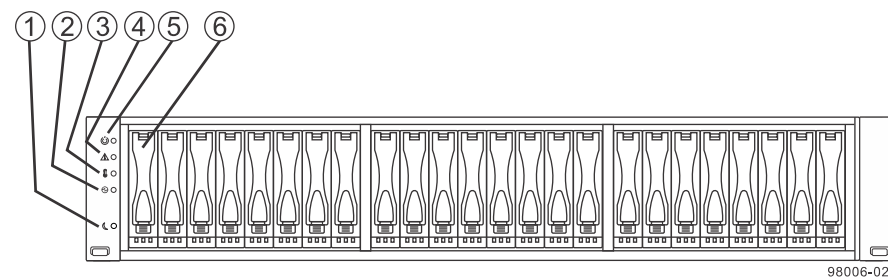
ATTENTION Possible data loss –If you remove all Fibre Channel Host Interface Cards (HICs) from a storage array and replace them with HICs of a different network protocol (such as iSCSI or SAS), you must first deactivate Remote Volume Mirroring (RVM) if it is activated. If you do not deactivate RVM before removing the Fibre Channel HICs, your system will lose data access and data loss might occur.

Figure 5. E2612 Controller-Drive Tray–Front View



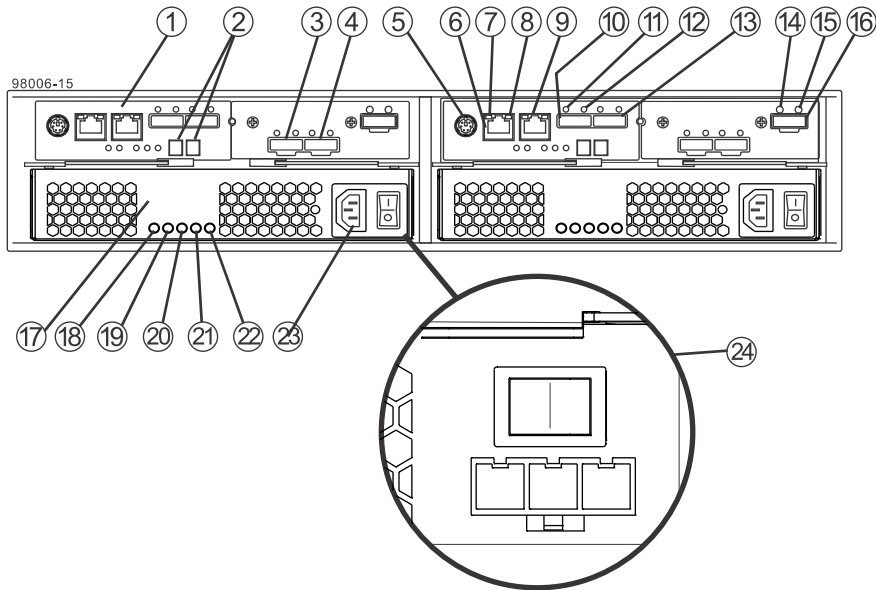
1. End Cap Locate LED
2. End Cap Service Action Required LED
3. End Cap Over-Temperature LED
4. End Cap Power LED
5. End Cap Standby Power LED
6. Drive Canister

Figure 6. E2624 Controller-Drive Tray– Front View



1. End Cap Standby Power LED
2. End Cap Power LED
3. End Cap Over-Temperature LED
4. End Cap Service Action Required LED
5. End Cap Locate LED
6. Drive Canister

Figure 7. E2612 or E2624 Duplex Configuration– Rear View



1. Controller A Canister
2. Seven-Segment Display
3. Host Interface Card Connector 1
4. Host Interface Card Connector 2
5. Serial Connector
6. Ethernet Connector 1
7. Ethernet Link Active LED
8. Ethernet Link Rate LED
9. Ethernet Connector 2
10. Base Host SFF-8088 Connector 2 (Native)
11. Host Link 2 Fault LED
12. Host Link 2 Active LED
13. Base Host SFF-8088 Connector 1 (Native)
14. ESM Expansion Fault LED
15. ESM Expansion Active LED
16. Expansion SFF-8088 Port Connector
17. Power-Fan Canister
18. Standby Power LED
19. Power-Fan DC Power LED
20. Power-Fan Service Action Allowed LED
21. Power-Fan Service Action Required LED
22. Power-Fan AC Power LED
23. Power-Fan AC Power Connector and Switch

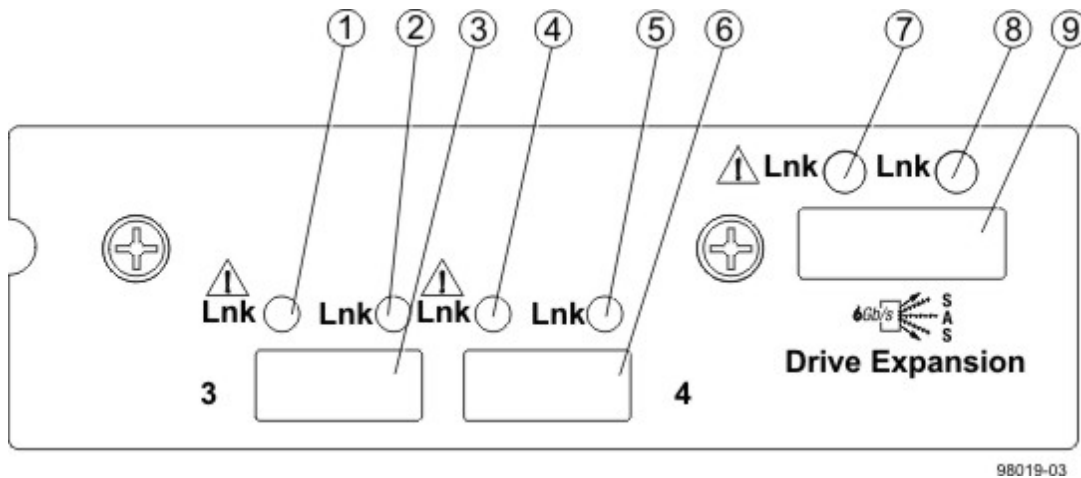
24. Power-Fan DC Power Connector and Switch

Figure 8. E2612 or E2624 Right-Rear Subplate with No Host Interface Card



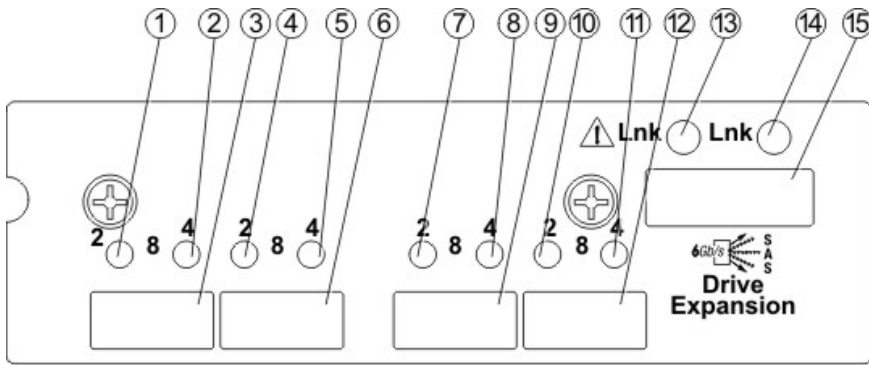
1. ESM Expansion Fault LED
2. ESM Expansion Active LED
3. Expansion SFF-8088 Port Connector

Figure 9. E2612 or E2624 Right-Rear Subplate with a SAS Host Interface Card



1. Host Interface Card Link 3 Up LED
2. Host Interface Card Link 3 Active LED
3. SFF-8088 Host Interface Card Connector 3
4. Host Interface Card Link 4 Up LED
5. Host Interface Card Link 4 Active LED
6. SFF-8088 Host Interface Card Connector 4
7. ESM Expansion Fault LED
8. ESM Expansion Active LED
9. Expansion SFF-8088 Port Connector

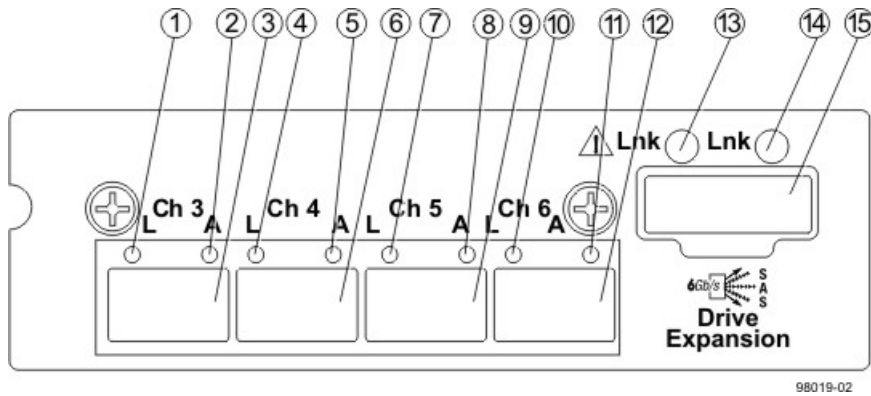
Figure 10. E2612 or E2624 Right-Rear Subplate with an FC Host Interface Card



98019-01

1. Host Interface Card Link 3 Up LED
2. Host Interface Card Link 3 Active LED
3. FC Host Interface Card Connector 3
4. Host Interface Card Link 4 Up LED
5. Host Interface Card Link 4 Active LED
6. FC Host Interface Card Connector 4
7. Host Interface Card Link 5 Up LED
8. Host Interface Card Link 5 Active LED
9. FC Host Interface Card Connector 5
10. Host Interface Card Link 6 Up LED
11. Host Interface Card Link 6 Active LED
12. FC Host Interface Card Connector 6
13. ESM Expansion Fault LED
14. ESM Expansion Active LED
15. Expansion SFF-8088 Port Connector

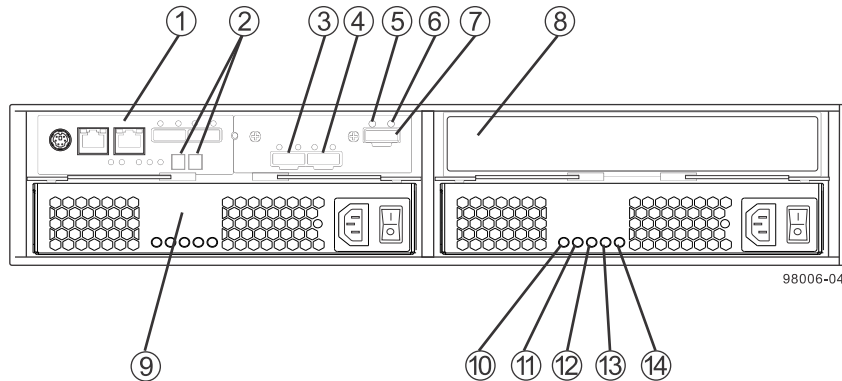
Figure 11. E2612 or E2624 Right-Rear Subplate with a 1-Gb iSCSI Host Interface Card



98019-02

1. Host Interface Card Link 3 Up LED
2. Host Interface Card Link 3 Active LED
3. iSCSI Host Interface Card Connector 3
4. Host Interface Card Link 4 Up LED
5. Host Interface Card Link 4 Active LED
6. iSCSI Host Interface Card Connector 4
7. Host Interface Card Link 5 Up LED
8. Host Interface Card Link 5 Active LED
9. iSCSI Host Interface Card Connector 5
10. Host Interface Card Link 6 Up LED
11. Host Interface Card Link 6 Active LED
12. iSCSI Host Interface Card Connector 6
13. ESM Expansion Fault LED
14. ESM Expansion Active LED
15. Expansion SFF-8088 Port Connector

Figure 12. E2612 or E2624 Controller-Drive Tray Simplex Configuration –Rear View



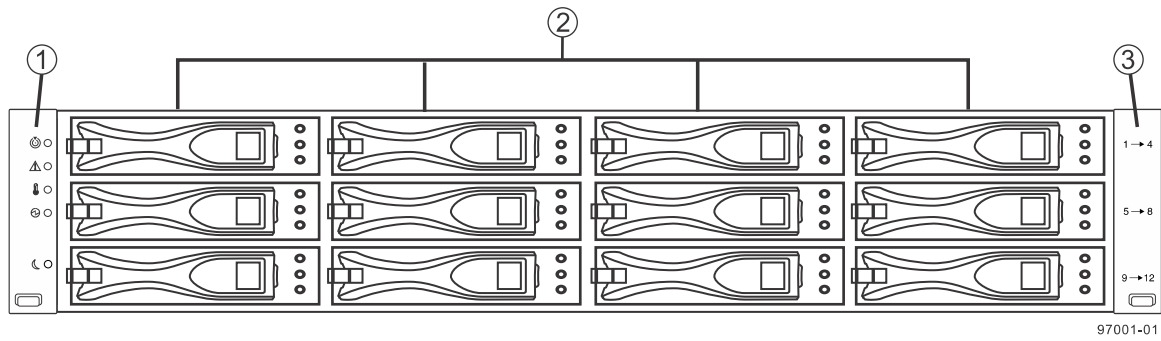
1. Controller A Canister
2. Seven-Segment Display
3. Host Interface Card Connector 1
4. Host Interface Card Connector 2
5. ESM Expansion Fault LED
6. ESM Expansion Active LED
7. Expansion Port SFF-8088 Connector
8. Controller Air Blocker
9. Power-Fan A Canister (optional)
10. Standby Power LED
11. Power-Fan DC Power LED
12. Power-Fan Service Action Allowed LED
13. Power-Fan Service Action Required LED
14. Power-Fan AC Power LED

NOTE In a simplex configuration, the Controller Air Blocker must be kept in place to ensure proper air flow to the components within the canister.

ATTENTION Possible equipment damage –You must use the supported drives in the drive tray to ensure proper performance. For information about supported drives, contact a Technical Support Representative.

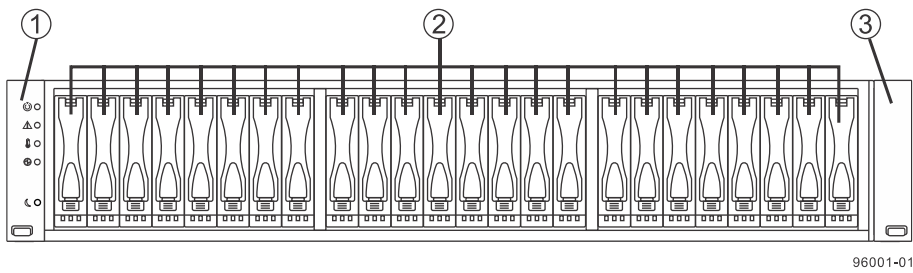
ATTENTION Risk of equipment malfunction –To avoid exceeding the functional and environmental limits, install only drives that have been provided or approved by the original manufacturer. Not all controller-drive trays are shipped with pre-populated drives. System integrators, resellers, system administrators, or users of the controller-drive tray can install the drives.

Figure 13. DE1600 Drive Tray–Front View



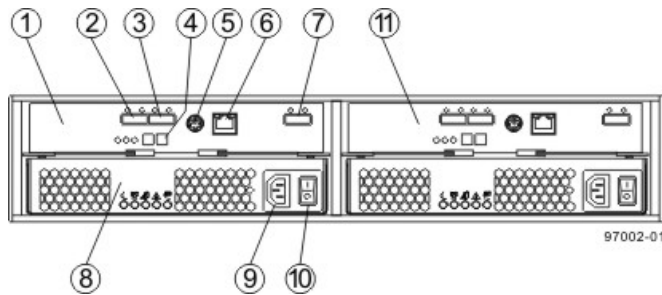
1. Left End Cap (Has the Drive Tray LEDs)
2. Drives
3. Right End Cap

Figure 14. DE5600 Drive Tray–Front View



1. Left End Cap (Has the Drive Tray LEDs)
2. Drives
3. Right End Cap

Figure 15. DE1600 Drive Tray or DE5600 Drive Tray with AC Power Option –Rear View



1. ESM A Canister
2. Expansion Port SFF-8088 Connector 1 (IN)
3. Expansion Port SFF-8088 Connector 2 (IN)
4. Seven-Segment Display Indicators
5. Serial Connector
6. Ethernet Connector
7. Expansion Port SFF-8088 Connector (OUT)
8. Power-Fan Canister
9. Power Connector
10. Power Switch
11. ESM B Canister

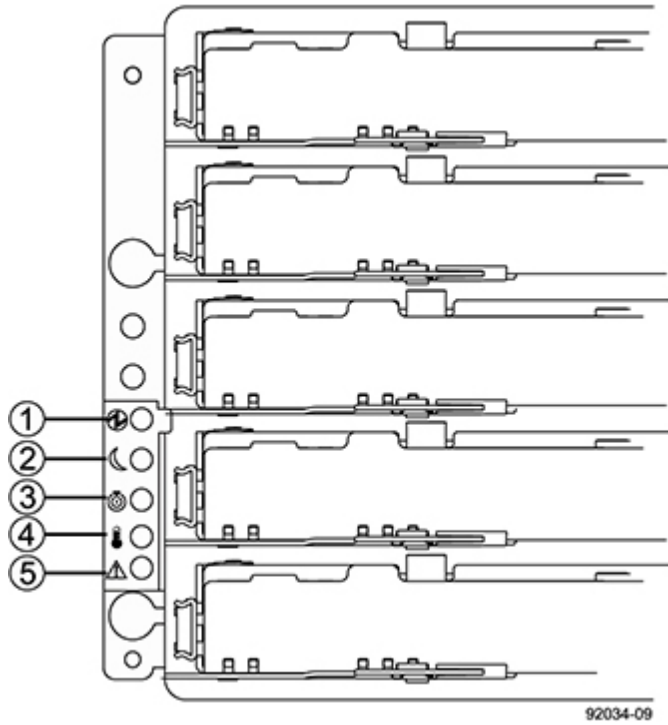
Things to Know – Taking a Quick Glance at the Hardware in a E2660 Controller-Drive Tray Configuration

- iSCSI host ports do not support the Data Assurance (DA) premium feature.
- The top of the controller-drive tray is the side with labels.
- The configuration of the host ports might appear different on your system depending on which host interface card configuration is installed.

NOTE To maintain a uniform airflow across all drive drawers, the controller-drive tray must be configured with a minimum of 20 drives. Slots 1, 4, 7, and 10 in the front row of each of the five drive drawers must have a drive installed in these locations.

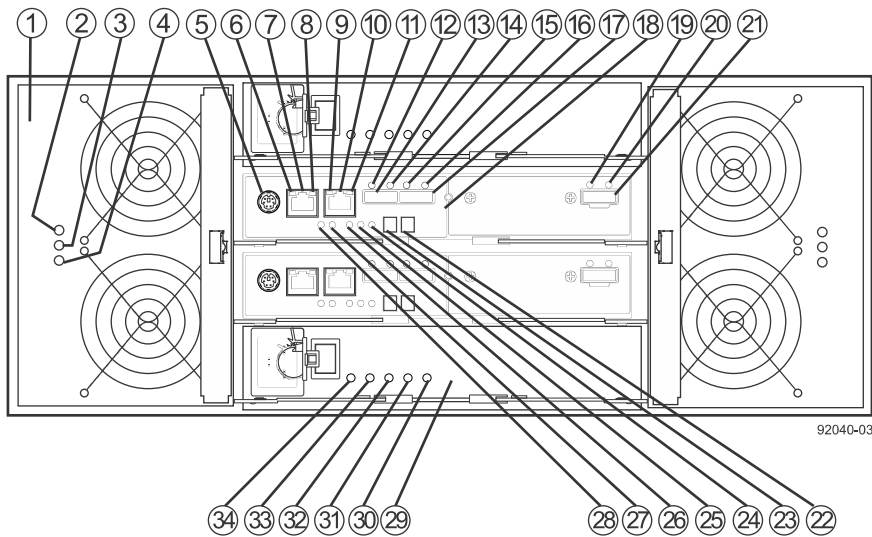
ATTENTION Possible data loss –If you remove all Fibre Channel Host Interface Cards (HICs) from a storage array and replace them with HICs of a different network protocol (such as iSCSI or SAS), you must first deactivate Remote Volume Mirroring (RVM) if it is running. If you do not deactivate RVM before removing the Fibre Channel HICs, your system will lose data access and data loss may occur.

Figure 16. E2660 Controller-Drive Tray–Front View with Bezel Removed



- 1. End Cap Power LED
- 2. End Cap Standby Power LED
- 3. End Cap Locate LED
- 4. End Cap Over-Temperature LED
- 5. End Cap Service Action Required LED

Figure 17. E2660 Controller-Drive Tray Duplex Configuration – Rear View



- 1. Fan Canister
- 2. Fan Canister Power LED

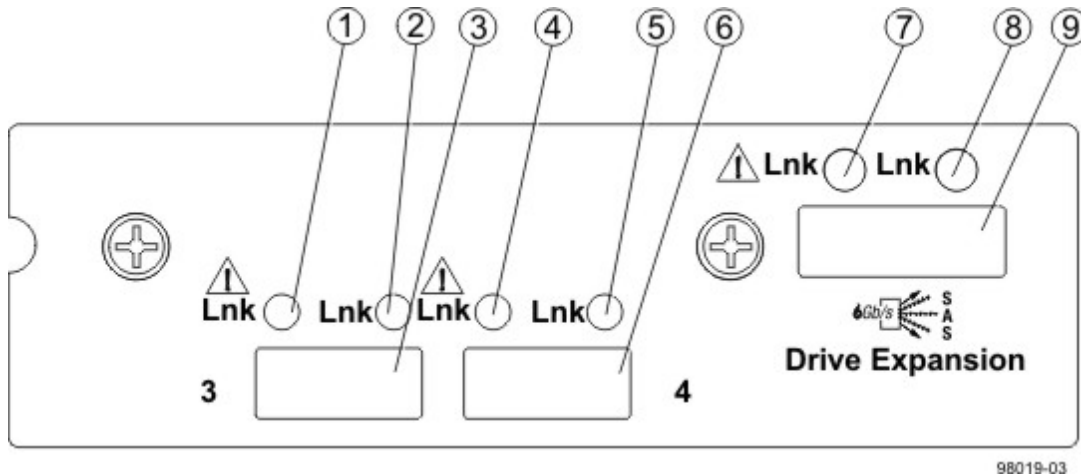
3. Fan Canister Service Action Required LED
4. Fan Canister Service Action Allowed LED
5. Serial Connector (PS2 to DB9 connector required)
6. Ethernet Link 1 Active LED
7. Ethernet Connector 1
8. Ethernet Link 1 Rate LED
9. Ethernet Link 2 Active LED
10. Ethernet Connector 2
11. Ethernet Link 2 Rate LED
12. Host Link 2 Fault LED
13. Base Host SFF-8088 Connector 2
14. Host Link 2 Active LED
15. Host Link 1 Fault LED
16. Host Link 1 Active LED
17. Base Host SFF-8088 Connector 1 (Native)
18. Controller A Canister
19. ESM Expansion Fault LED
20. ESM Expansion Active LED
21. Expansion SFF-8088 Port Connector
22. Second Seven-Segment Display Field
23. First Seven-Segment Display Field
24. Cache Active LED
25. Controller A Service Action Required LED
26. Controller A Service Action Allowed LED
27. Battery Service Action Required LED
28. Battery Charging LED
29. Power Canister
30. Power Canister AC Power LED
31. Power Canister Service Action Required LED
32. Power Canister Service Action Allowed LED
33. Power Canister DC Power LED
34. Power Canister Standby Power LED

Figure 18. E2660 Right-Rear Subplate with No Host Interface Card



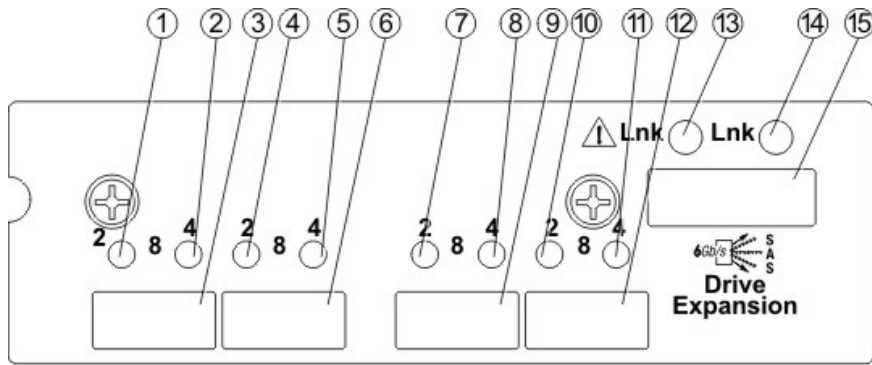
1. ESM Expansion Fault LED
2. ESM Expansion Active LED
3. Expansion SFF-8088 Port Connector

Figure 19. E2660 Right-Rear Subplate with a SAS Host Interface Card



1. Host Interface Card Link 3 Up LED
2. Host Interface Card Link 3 Active LED
3. SFF-8088 Host Interface Card Connector 3
4. Host Interface Card Link 4 Up LED
5. Host Interface Card Link 4 Active LED
6. SFF-8088 Host Interface Card Connector 4
7. ESM Expansion Fault LED
8. ESM Expansion Active LED
9. Expansion SFF-8088 Port Connector

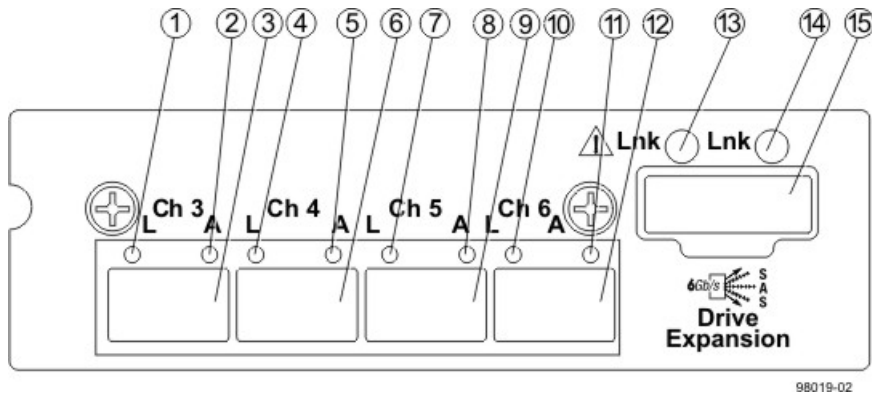
Figure 20. E2660 Right-Rear Subplate with an FC Host Interface Card



98019-01

1. Host Interface Card Link 3 Up LED
2. Host Interface Card Link 3 Active LED
3. FC Host Interface Card Connector 3
4. Host Interface Card Link 4 Up LED
5. Host Interface Card Link 4 Active LED
6. FC Host Interface Card Connector 4
7. Host Interface Card Link 5 Up LED
8. Host Interface Card Link 5 Active LED
9. FC Host Interface Card Connector 5
10. Host Interface Card Link 6 Up LED
11. Host Interface Card Link 6 Active LED
12. FC Host Interface Card Connector 6
13. ESM Expansion Fault LED
14. ESM Expansion Active LED
15. Expansion SFF-8088 Port Connector

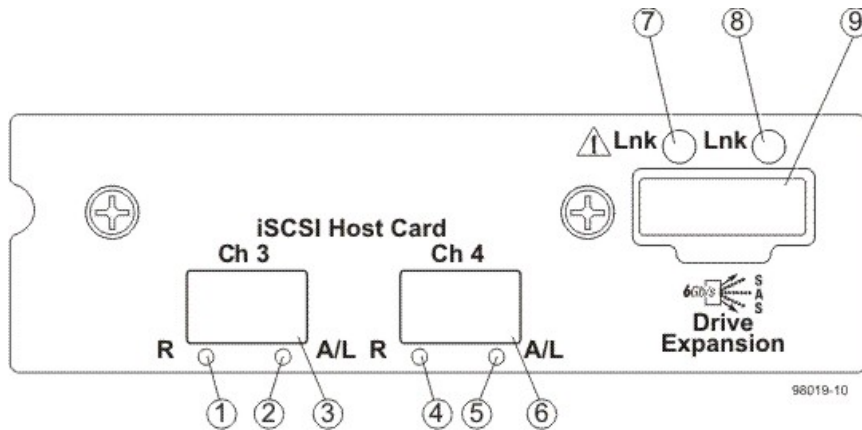
Figure 21. E2660 Right-Rear Subplate with a 1-Gb iSCSI Host Interface Card



98019-02

1. Host Interface Card Link 3 Up LED
2. Host Interface Card Link 3 Active LED
3. iSCSI Host Interface Card Connector 3
4. Host Interface Card Link 4 Up LED
5. Host Interface Card Link 4 Active LED
6. iSCSI Host Interface Card Connector 4
7. Host Interface Card Link 5 Up LED
8. Host Interface Card Link 5 Active LED
9. iSCSI Host Interface Card Connector 5
10. Host Interface Card Link 6 Up LED
11. Host Interface Card Link 6 Active LED
12. iSCSI Host Interface Card Connector 6
13. ESM Expansion Fault LED
14. ESM Expansion Active LED
15. Expansion SFF-8088 Port Connector

Figure 22. E2660 Right-Rear Subplate with a 10-Gb iSCSI Host Interface Card



1. Host Interface Card Link 3 Up LED
2. Host Interface Card Link 3 Active LED
3. iSCSI Host Interface Card Connector 3
4. Host Interface Card Link 4 Up LED
5. Host Interface Card Link 4 Active LED
6. iSCSI Host Interface Card Connector 4
7. ESM Expansion Fault LED
8. ESM Expansion Active LED
9. Expansion SFF-8088 Port Connector

ATTENTION Possible equipment damage –You must use the supported drives in the drive tray to ensure proper performance. For information on supported drives, contact a Technical Support Representative.

ATTENTION Risk of equipment malfunction –To avoid exceeding the functional and environmental limits, install only drives that have been provided or approved by the original manufacturer. Not all controller-drive trays are shipped with prepopulated drives. System integrators, resellers, system administrators, or users of the controller-drive tray can install the drives.

Figure 23. DE6600 Drive Tray–Front View with Bezel

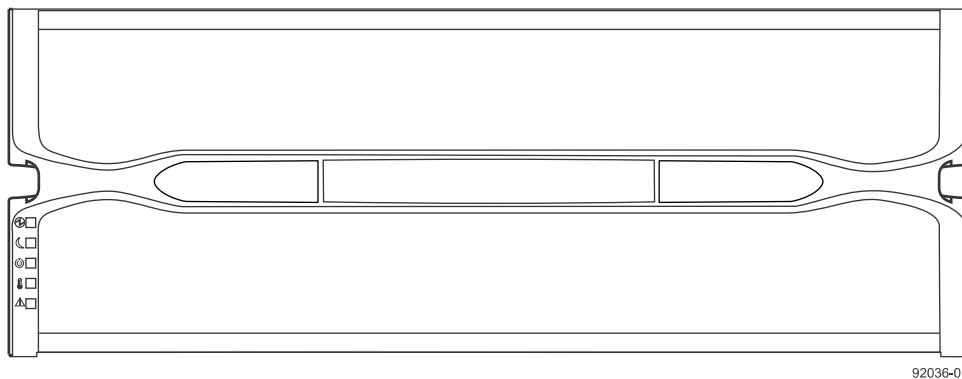


Figure 24. DE6600 Drive Tray–Front View with Bezel Removed

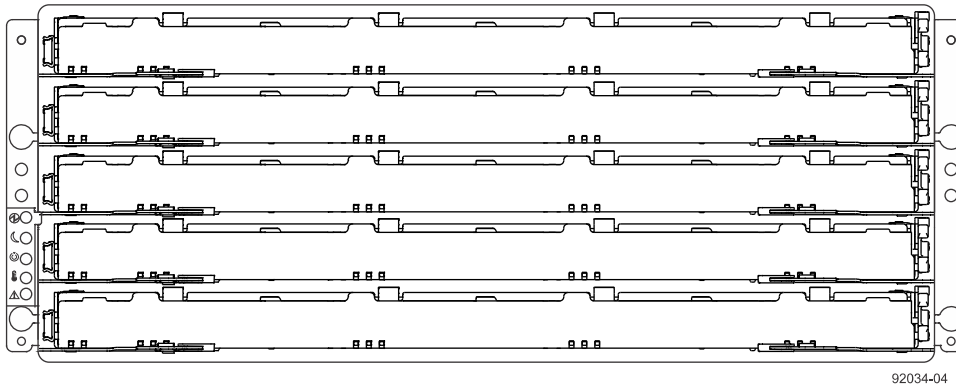
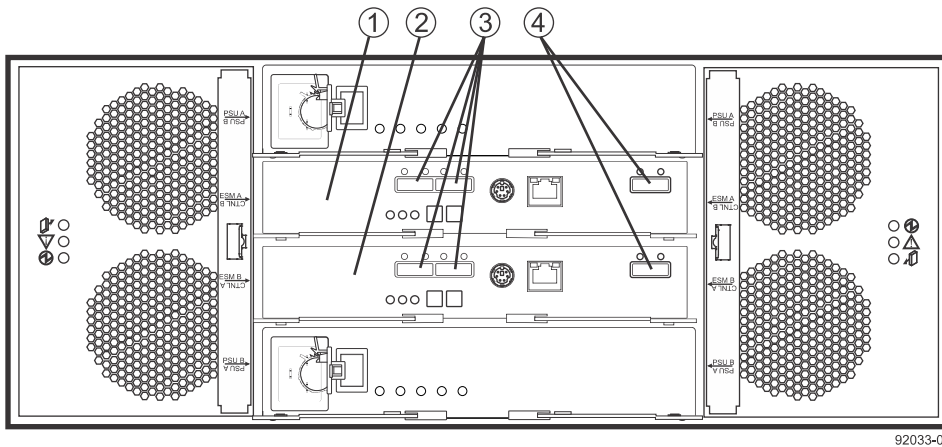


Figure 25. DE6600 Drive Tray–Rear View



1. ESM A
2. ESM B
3. SAS IN Connectors
4. Expansion Connectors

For Additional Information on the E2600 Controller-Drive Tray Configuration

Refer to the *Storage System Site Preparation Guide* for information about the installation requirements of the various E2600 storage array components.

Step 2 – Installing and Configuring the Switches

Things to Know –Switches, Routers, and SFPs

NOTE Most of the switches, as shipped from the vendor, require an update to their firmware to work correctly with the storage array.

Depending on the configuration of your storage array, you might use Fibre Channel switches, iSCSI switches, or SAS switches.

The switches in the following table are certified for use with an E2600 storage array and an E2660 storage array.

Table 6. Supported Fibre Channel Switches and Routers

Vendor	Model	Data Rate
Brocade	200E	4 Gb
	4100	4 Gb
	48000	4 Gb
	5000	4 Gb
	300	8 Gb
	5100	8 Gb
	5300	8 Gb
	7500	4 Gb
	7800	8 Gb
	DCX	8 Gb
Cisco	9506	4 Gb
	9509	4 Gb
	9216	4 Gb
	9216i	4 Gb
	9120	4 Gb
	914x	4 Gb
	9513	4 Gb, 8 Gb
	9020	4 Gb
	9222i	8 Gb
	9134	4 Gb
QLogic	SANbox5200	4 Gb
	SANbox3600	4 Gb
	SANbox3800	8 Gb
	SANbox5600	8 Gb
	SANbox5800	8 Gb
	SANbox9000	8 Gb

Vendor	Model	Data Rate
	6142	8 Gb

Table 7. Supported iSCSI Switches

Vendor	Model	Data Rate/Connection
Brocade	8000	10 GB / Optical
	Turbiron	10 GB / Optical
Cisco	Catalyst 3560	1 GB / RJ45
	Catalyst 3750G-24TS	1 GB / RJ45
	Nexus 5000	10 GB / Optical
Dell	8024	10 GB / Copper (RJ45)
	8024F	10 GB / Ethernet / SFP Plus (24-port)
PowerConnect	5324	1 GB / RJ45
	6024	1 GB / RJ45

Table 8. Supported SAS Switches

Vendor	Model	Version/Data Rate
LSI	6160	SAS 2.0 / 6 GB (16-port)
	6160	SAS 2.0 / 6 GB

If required, make the appropriate configuration changes for *each* switch that is connected to the storage array.

Refer to the switch's documentation for information about how to install the switch and how to use the configuration utilities that are supplied with the switch.

The SFPs in the following table apply only if you are using Fibre Channel network protocols.

Table 9. NetApp Supported SFPs

Vendor	Version/Data Rate
Avago	8G
	10G
Finisar	1G
	8G
	10G
JDSU	8G
	10G
Molex	8G
Opnext	10G

Refer to your Technical Support Representative for the latest information about new switches, routers, and SFPs that are tested and certified to work with various hardware and software combinations.

Procedure – Installing and Configuring Switches

1. Install your switch according to the vendor's documentation.
Refer to the switch's documentation for information about how to install the switch and how to use the configuration utilities that are supplied with the switch.
2. Refer to your Technical Support Representative to obtain this information:
 - The latest hardware compatibility information
 - The models of the switches that are supported
 - The firmware requirements and the software requirements for the switches
3. Update the switch's firmware by accessing it from the applicable switch vendor's website.
This update might require that you cycle power to the switch.
4. Find your switch in the following table to see whether you need to make further configuration changes. Use your switch's configuration utility to make the changes.

Table 10. Supported Switch Vendors and Required Configuration Changes

Switch Vendor	Configuration Changes Required?
Brocade	Yes Change the In-Order Delivery (IOD) option to ON.
Cisco	Yes Change the in-order-guarantee option to ON.
LSI	No
McData	No
QLogic	No
PowerConnect	No

Step 3 – Installing the Host Bus Adapters for the E2600 Controller-Drive Tray

Key Terms

HBA host port

The physical and electrical interface on the host bus adapter (HBA) that provides for the connection between the host and the controller. Most HBAs will have either one or two host ports. The HBA has a unique World Wide Identifier (WWID) and each HBA host port has a unique WWID.

host bus adapter (HBA)

A physical board that resides in the host. The HBA provides for data transfer between the host and the controllers in the storage array over the I/O host interface. Each HBA contains one or more physical ports.

HBA host port world wide name (WWN)

A 16-character unique name that is provided for each port on the host bus adapter (HBA).

Things to Know – Host Bus Adapters and Ethernet Network Interface Cards

- The E2600 controller-drive tray supports dual 6-Gb/s SAS host connections and optional host interface cards (HICs) for dual 6-Gb/s SAS, four 1-Gb/s iSCSI, two 10-Gb iSCSI, and four 8-Gb/s FC connections. The connections on a host must match the type (SAS HBAs for SAS, FC HBAs for FC, or iSCSI HBAs or Ethernet network interface cards [NICs] for iSCSI) of the HICs to which you connect them. For the best performance, HBAs for SAS and FC connections should support the highest data rate supported by the HICs to which they connect.
- For maximum hardware redundancy, you must install a minimum of two HBAs (for either SAS or FC host connections) or two NICs or iSCSI HBAs (for iSCSI host connections) in each host. Using both ports of a dual-port HBA or a dual-port NIC provides two paths to the storage array but does not ensure redundancy if an HBA or a NIC fails.
- Most of the HBAs, as shipped from the vendor, require updated firmware and software drivers to work correctly with the storage array. For information about the updates, refer to the website of the storage vendor to obtain certified versions.

Consult your Technical Support Representative to obtain information about the supported models of the HBAs and their requirements to make sure you have an acceptable configuration.

Procedure – Installing Fibre Channel Host Bus Adapters

1. Consult with your Technical Support Representative to verify that you have an acceptable configuration. Before installing a Host Bus Adapter (HBA) you must have the following information:
 - The latest hardware compatibility information

- The models of the HBAs that are supported
 - The firmware requirements and the software requirements for the HBAs
2. Install your HBA, including the appropriate version of the firmware, according to the vendor documentation.
If your operating system is either Windows Server 2008 Server Core, or Windows 2012 Sever, you might have additional installation requirements. Refer to the Microsoft Developers Network (MSDN) for more information about Windows Server 2008 Server Core. You can access these resources from www.microsoft.com.
 3. Install the latest version of the firmware/driver for the HBA. You can find the latest version of the firmware for the HBA at the storage vendor site.

NOTE If the SMagent is installed, you are finished with this procedure; if not, go to step 4. The remaining steps describe how to obtain the Fibre Channel HBA host port world wide name from the HBA BIOS utility.

4. Reboot or start your host.
5. While your host is booting, look for the prompt to access the HBA BIOS utility.
The actual prompts and screens vary depending on the vendor that provides the HBA. Also, some HBAs have software utilities that you can use to obtain the world wide name for the port instead of using the BIOS utility. If you are using a Fibre Channel switch, you can find the HBA host port world wide name of each port on the HBA from the name server of the switch.
6. Select each HBA to view its HBA host port world wide name.
7. Record the following information for each host and for each HBA connected to the storage array:
 - The name of each host
 - The HBAs in each host
 - The HBA host port world wide name of each port on the HBA

The following table shows examples of the host and HBA information that you must record.

Table 11. Examples of HBA Host Port World Wide Names

Host Name	Associated HBAs	HBA Host Port World Wide Name
ICTENGINEERING	Vendor x, Model y (dual port)	37:38:39:30:31:32:33:32 37:38:39:30:31:32:33:33
	Vendor a, Model y (dual port)	42:38:39:30:31:32:33:42 42:38:39:30:31:32:33:44
ICTFINANCE	Vendor a, Model b (single port)	57:38:39:30:31:32:33:52
	Vendor x, Model b (single port)	57:38:39:30:31:32:33:53

Step 4 – Installing the E2600 Controller-Drive Tray

Things to Know – General Installation

The power supplies meet standard voltage requirements for both domestic and worldwide operation.

NOTE Make sure that the combined power requirements of your trays do not exceed the power capacity of your cabinet. For power ratings on E2600 controller-drive trays and its related drive trays, refer to the *Storage System Site Preparation Guide*.

Procedure – Installing the E2612 Controller-Drive Tray or the E2624 Controller-Drive Tray

⚠ WARNING (W08) Risk of bodily injury –



>18 kg (39.7 lbs)

Two persons are required to safely lift the component.

⚠ WARNING (W05) Risk of bodily injury – If the bottom half of the cabinet is empty, do not install components in the top half of the cabinet. If the top half of the cabinet is too heavy for the bottom half, the cabinet might fall and cause bodily injury. Always install a component in the lowest available position in the cabinet.

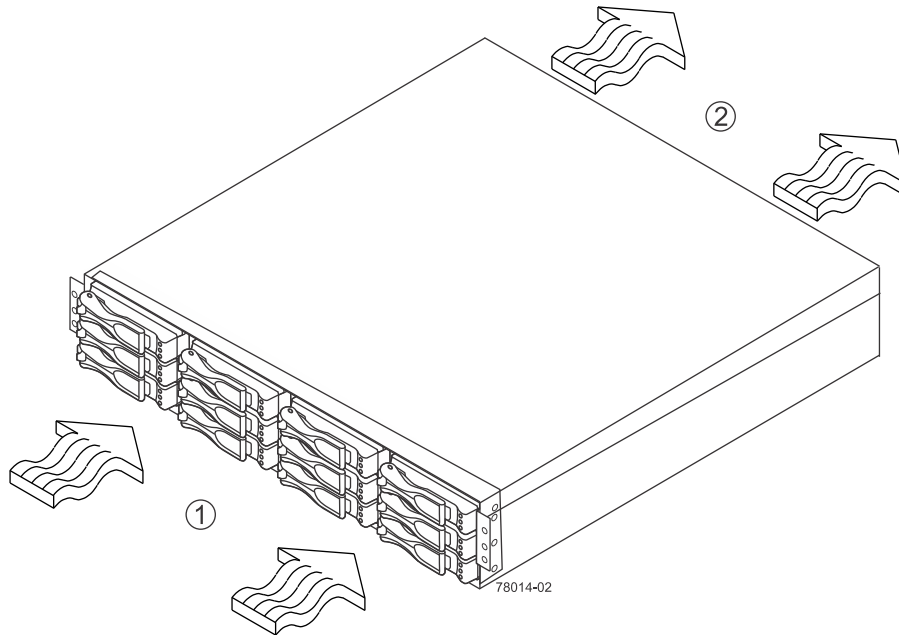
You can install the controller-drive tray into an industry-standard cabinet.

This procedure describes how to install the mounting rails into an industry-standard cabinet.

ATTENTION Possible hardware damage – To prevent electrostatic discharge damage to the tray, use proper antistatic protection when handling tray components.

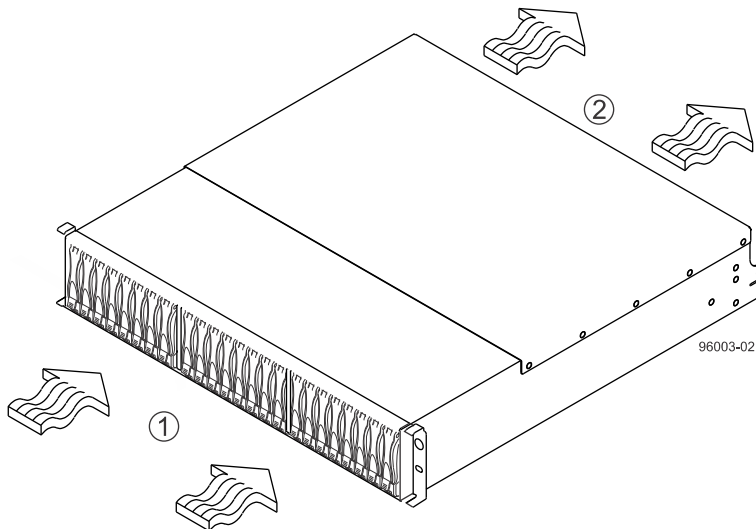
1. Make sure that the cabinet is in the final location. Make sure that the cabinet installation site meets the clearance requirements for air flow as shown in [Figure 26](#) and [Figure 27](#).

Figure 26. E2612 Controller-Drive Tray Airflow and Clearance Requirements



1. 76 cm (30 in.) clearance in front of the cabinet
2. 61 cm (24 in.) clearance behind the cabinet

Figure 27. E2624 Controller-Drive Tray Airflow and Clearance Requirements



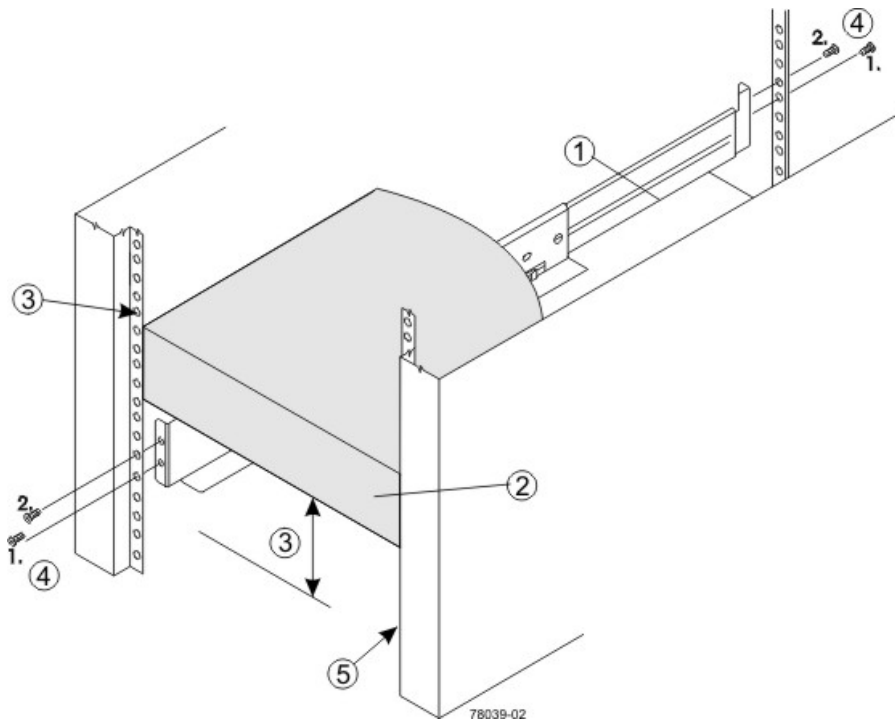
1. 76 cm (30 in.) clearance in front of the cabinet
2. 61 cm (24 in.) clearance behind the cabinet

NOTE Fans pull air through the tray from front to back across the drives.

2. Lower the feet on the cabinet, if required, to keep it from moving.
3. Remove the controller-drive tray and all contents from the shipping carton.

4. Position the mounting rails in the cabinet. For more information, refer to the installation instructions that are included with your mounting rails.

Figure 28. Positioning the Mounting Rails in the Cabinet



1. Mounting Rail
2. Existing Tray
3. Clearance Above and Below the Existing Tray
4. Screws for Securing the Mounting Rail to the Cabinet (Front and Rear)
5. Industry-standard Cabinet

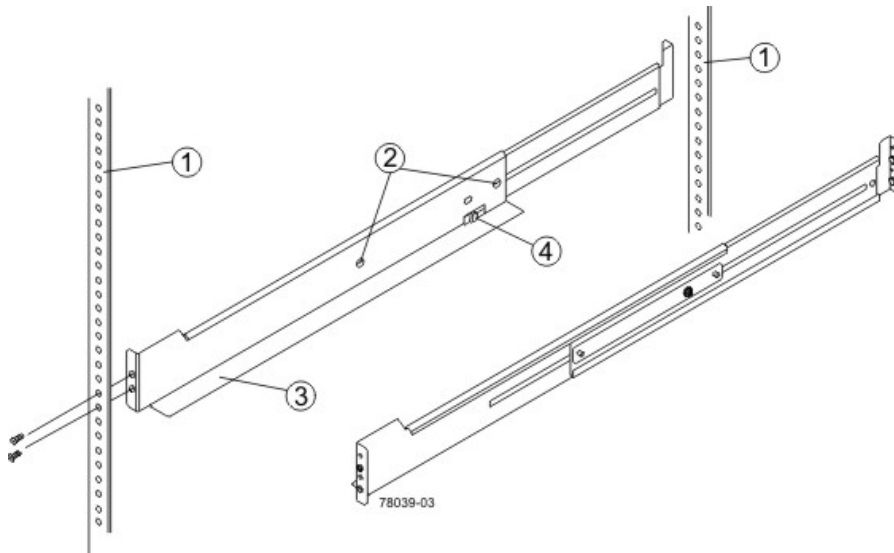
- If you are installing the mounting rails above an existing tray, position the mounting rails directly above the existing tray.
- If you are installing the mounting rails below an existing tray, allow 8.7-cm (3.4-in.) clearance below the existing tray for E5512 controller-drive trays and 8.9-cm (3.5 in) for E2624 controller-drive trays.

ATTENTION Risk of equipment malfunction – To avoid exceeding the functional and environmental limits, install only drives that have been provided or approved by NetApp, Inc. Not all controller-drive trays are shipped with pre-populated drives. System integrators, resellers, system administrators, or users of the controller-drive tray can install the drives.

5. Attach the mounting rails to the cabinet.

- a. Make sure that the adjustment screws on the mounting rail are loose so that the mounting rail can extend or contract as needed.

Figure 29. Attaching the Mounting Rails to the Cabinet

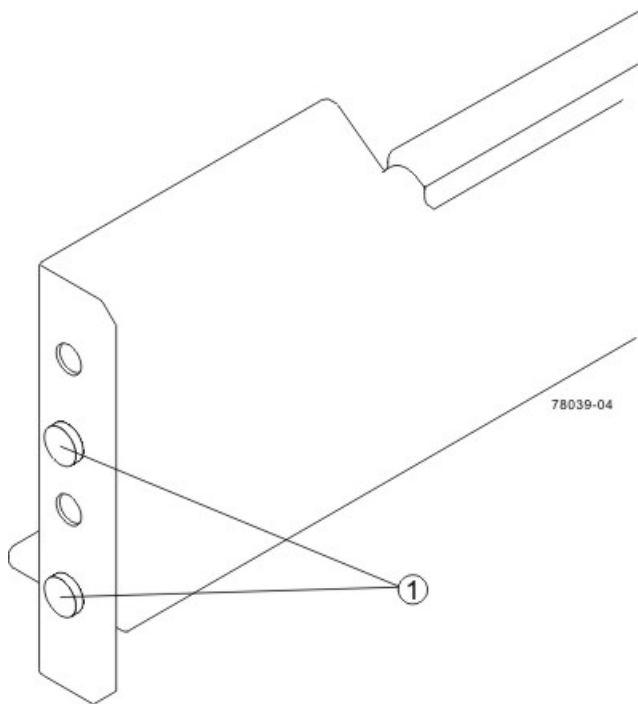


- 1. Cabinet Mounting Holes
 - 2. Adjustment Screws for Locking the Mounting Rail Length
 - 3. Mounting Rails
 - 4. Clip for Securing the Rear of the Controller-Drive Tray
- b. Place the mounting rail inside the cabinet, and extend the mounting rail until the flanges on the mounting rail touch the inside of the cabinet.
 - c. Make sure that the alignment spacers on the front flange of the mounting rail fit into the mounting holes in the cabinet.

The front flange of each mounting rail has two alignment spacers. The alignment spacers are designed to fit into the mounting holes in the cabinet. The alignment spacers help position and hold the mounting rail.

NOTE If the cabinet in which you are installing this tray has square holes, insert the shoulder washers into the square holes when mounting the rail.

Figure 30. Alignment Spacers on the Mounting Rail

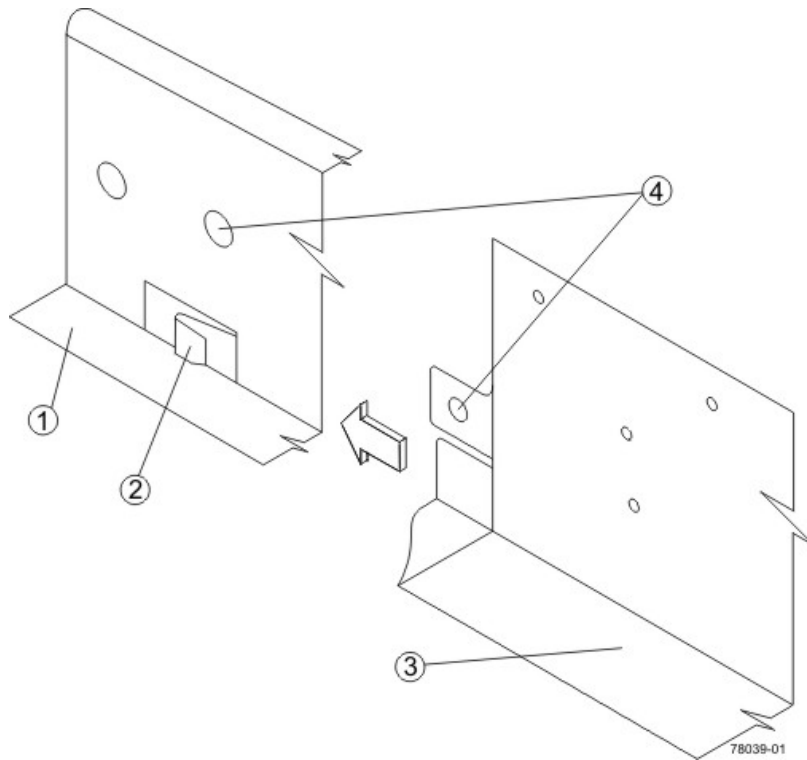


1. Alignment Spacers

- d. Insert one M5 screw through the front of the cabinet and into the top captured nut in the mounting rail. Tighten the screw.
 - e. Insert two M5 screws through the rear of the cabinet and into the captured nuts in the rear flange in the mounting rail. Tighten the screws.
 - f. Tighten the adjustment screws on the mounting rail.
 - g. Repeat substep a through substep f to install the second mounting rail.
6. With the help of one other person, slide the rear of the controller-drive tray onto the mounting rails. The rear edge of the controller-drive tray must fit into the clip on the mounting rail. The controller-drive tray is correctly aligned when these conditions are met:
- The mounting holes on the front flanges of the drive tray align with the mounting holes on the front of the mounting rails. See item 4 in the following figure.
 - The rear edge of the controller-drive tray sheet metal fits into the clip on the mounting rail.

- The holes in the controller-drive tray sheet metal for the rear hold-down screws align with the captured nuts in the side of the mounting rails.

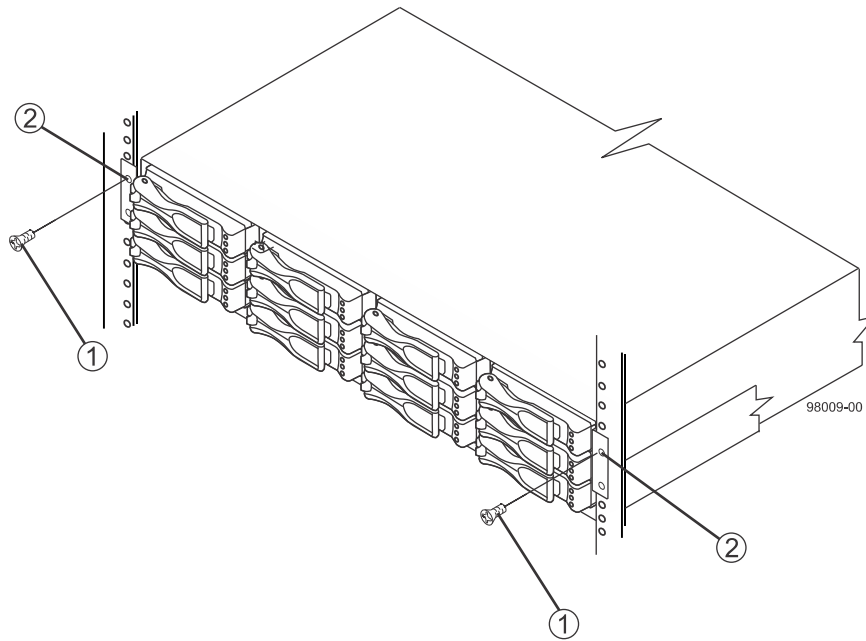
Figure 31. Sliding the Controller-Drive Tray into the Clip on the Mounting Rail



1. Mounting Rail
 2. Clip
 3. Partial View of the Controller-Drive Tray Rear Sheet Metal
 4. Mounting Holes
7. Secure the front of the controller-drive tray to the cabinet. Use the two screws to attach the flange on each side of the front of the controller-drive tray to the mounting rails.
- a. Insert one M5 screw through the bottom hole of a flange on the controller-drive tray so that the screw goes through the cabinet rail and engages the bottom captured nut in the mounting rail. Tighten the screw.

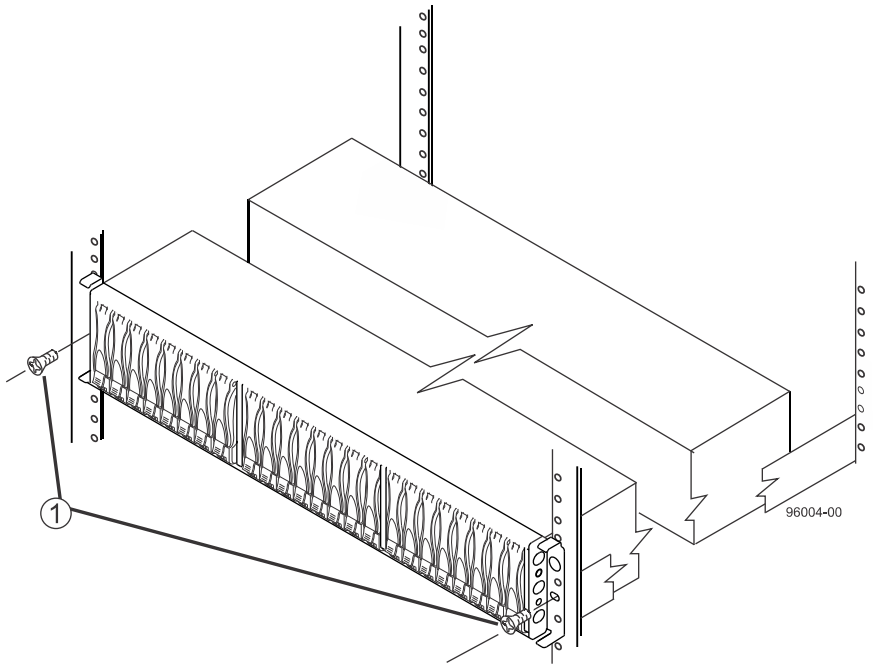
b. Repeat substep a for the second flange.

Figure 32. Securing the E2612 Controller-Drive Tray to the Cabinet



- 1. Screw
- 2. Mounting Hole

Figure 33. Securing the E2624 Controller-Drive Tray to the Cabinet



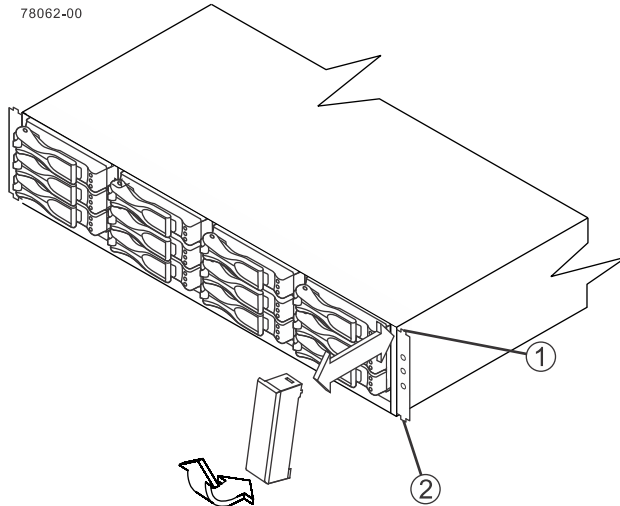
1. Screw

NOTE The rear of the controller-drive tray contains two controllers. The top of the controller-drive tray is the side with the labels.

8. Secure the side of the controller-drive tray to the mounting rails by performing these substeps:
 - a. Insert one M4 screw through the side sheet metal of the controller-drive tray into the captured nut on the side of the mounting rail. Tighten the screw.
 - b. Repeat substep a for the other side.
9. Attach the plastic end caps onto the front of the controller-drive tray.
 - a. Put the top of the end cap on the hinge tab that is part of the controller-drive tray mounting flange.

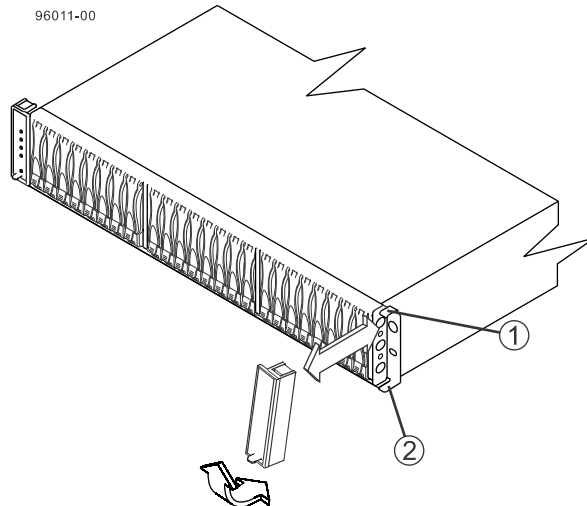
- b. Gently press on the bottom of the end cap until it snaps into place over the retainer on the bottom of the controller-drive tray mounting flange.

Figure 34. Attaching the End Caps to the E2612 Controller-Drive Tray



- 1. Hinge Tab
- 2. Retainer

Figure 35. Attaching the End Caps to the E2624 Controller-Drive Tray



- 1. Hinge Tab
- 2. Retainer

10. Install the drive trays.

Procedure – Installing the E2660 Controller-Drive Tray

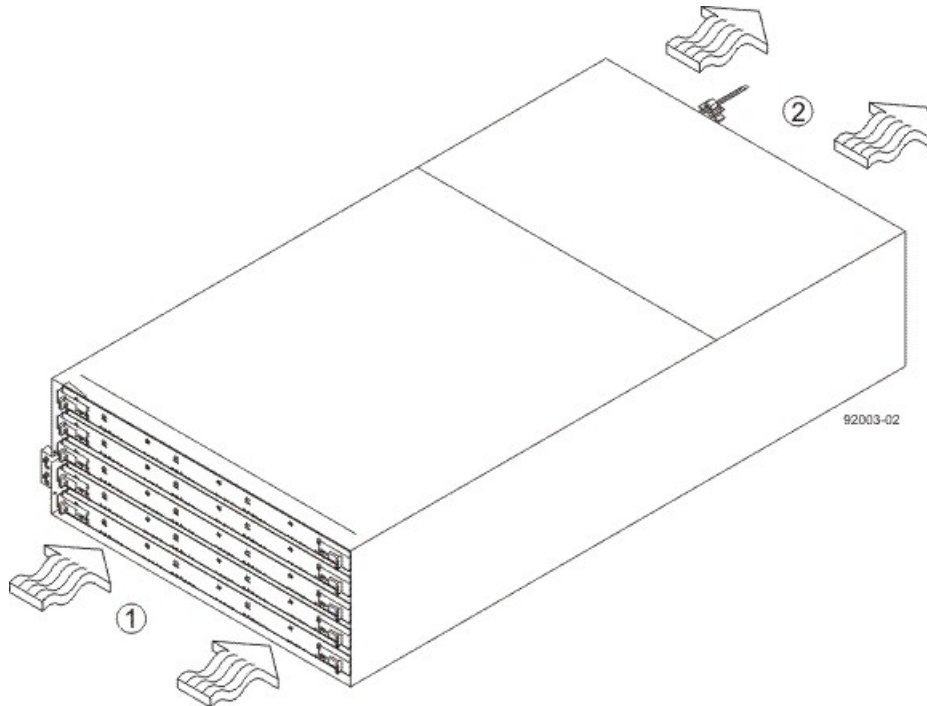
You can install the E2660 controller-drive tray into an industry-standard cabinet, provided it has a depth of 100 cm (40 in.).

A minimum depth of 76 cm (30 in.) between the front EIA support rails and the rear EIA support rails is required.

NOTE If you are mounting the E2660 controller-drive tray in a cabinet with square holes, use the eight shoulder washers in the rail kit to align the screws in the holes (see step 4 through step 7).

1. Make sure that the cabinet is in the final location. Make sure that you meet the clearance requirements shown in the following figure.

Figure 36. E2660 Controller-Drive Tray Airflow Direction and Clearance Requirements



1. 81 cm (32 in.) clearance in front of the cabinet
2. 61 cm (24 in.) clearance behind the cabinet

NOTE Fans pull air through the controller-drive tray from front to back across the drives.

2. Lower the feet on the cabinet to keep the cabinet from moving.

⚠ WARNING (W10) Risk of bodily injury –



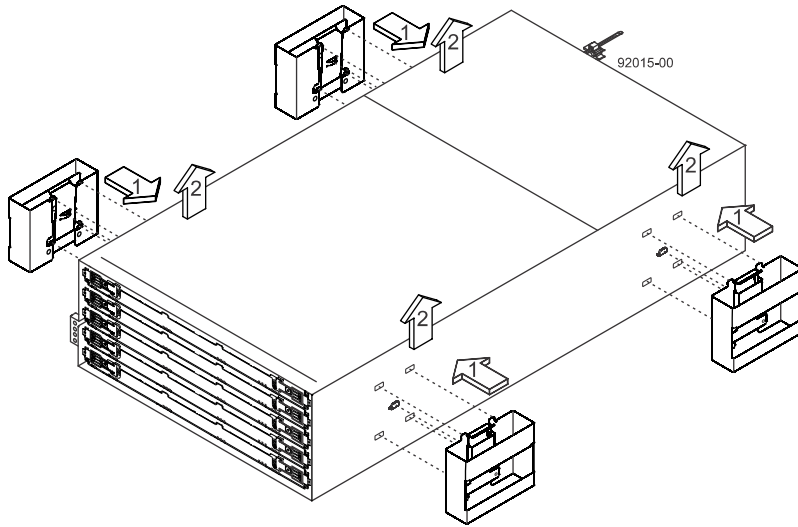
>55 kg (121.3 lbs)

Four or more persons are required to safely lift the component.

3. Before removing the controller-drive tray and all of the contents from the shipping carton, locate the tray handles and attach them to the controller-drive tray:
 - a. Align the handle just under the thumb latch.

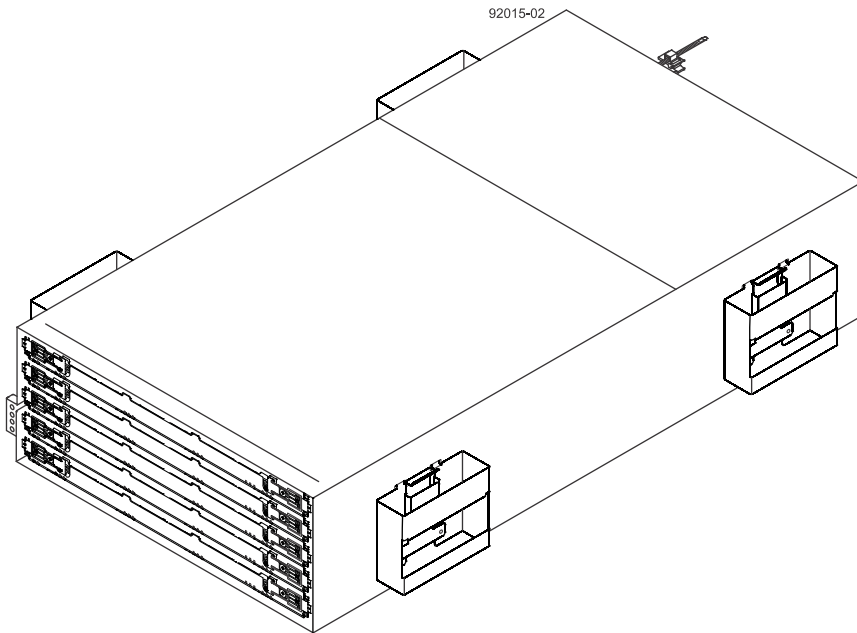
b. Push the handle up until it clicks in place with the thumb latch.

Figure 37. Attaching the Tray Handles to the Controller-Drive Tray



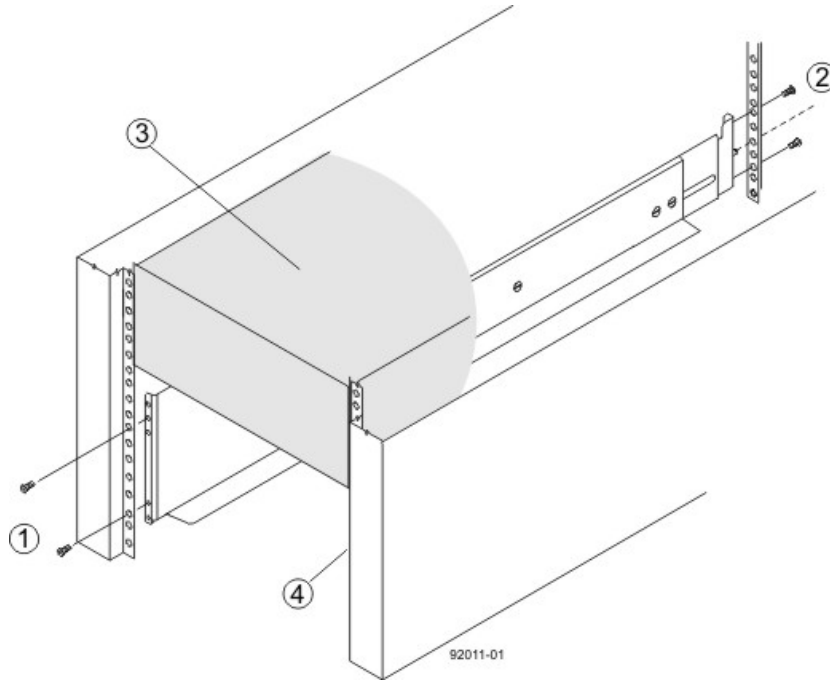
4. With the help of at least three other persons, remove the controller-drive tray and all of the contents from the shipping carton, using the four controller-drive tray handles (two to a side) as shown in the following figure. Set the controller-drive tray.

Figure 38. E2660 Controller-Drive Tray with Controller-Drive Tray Handles (Two on Each Side)



5. Position the mounting rails in the cabinet as shown in the following figure.

Figure 39. Positioning the Mounting Rails in the Cabinet



1. Screws for Securing the Mounting Rail to the Cabinet (Front)
2. Screws for Securing the Mounting Rail to the Cabinet (Rear)
3. Existing Tray
4. Industry-standard Cabinet

- If you are installing the mounting rails above an existing tray, position the mounting rails directly above the tray.
- If you are installing the mounting rails below an existing tray, allow 17.8-cm (7-in.) vertical clearance for the E2660 controller-drive tray.

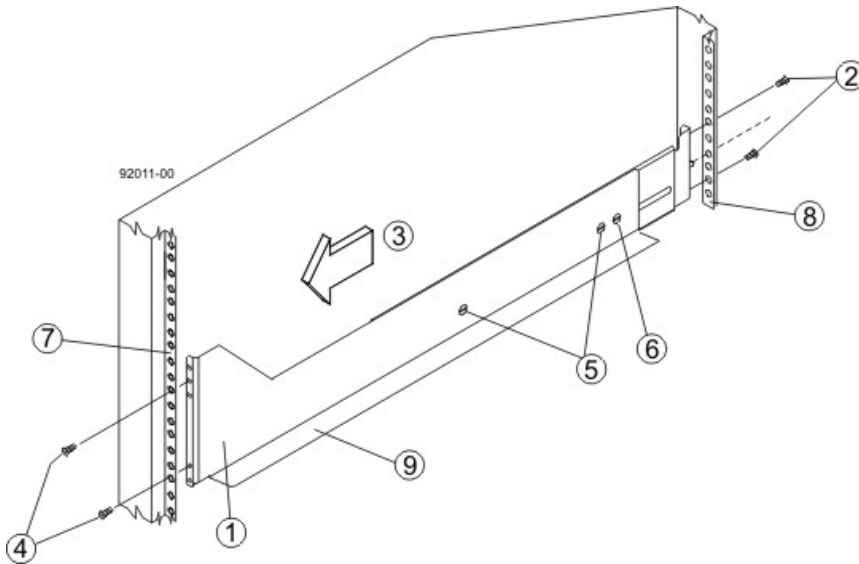
6. To attach the mounting rails to the cabinet, perform one of the following actions:

- If you are using the long, fixed-size mounting rails, go to step [7](#).
- If you are using the shorter adjustable mounting rails, go to step [8](#).

7. Attach the long, fixed-size rails to the cabinet.

- a. Make sure that the adjustment screws on the mounting rail are loose so that the mounting rail can extend or contract as needed.

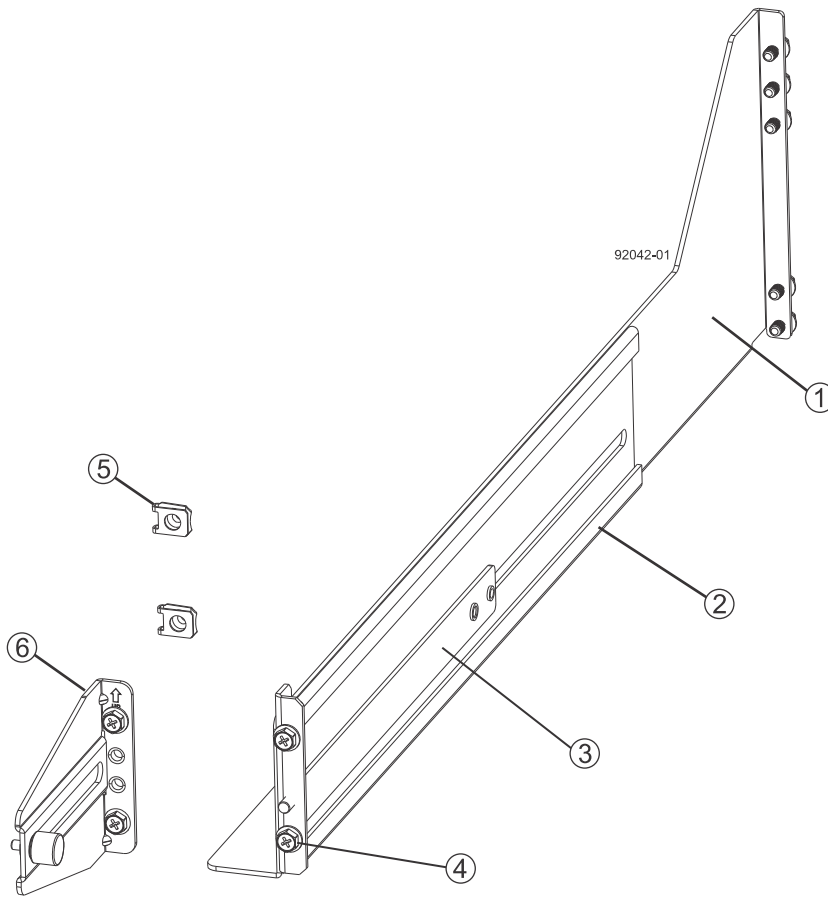
Figure 40. Attaching the Long, Fixed-Size Mounting Rails to the Cabinet



1. Front of the Mounting Rail
 2. Two M5 Screws for the Rear EIA Support Rail
 3. Front of the Cabinet
 4. Two M5 Screws for the Front EIA Support Rail
 5. Adjustment Screws
 6. Rear Hold-Down Screw
 7. Cabinet Mounting Holes on the Front EIA Support Rail
 8. Cabinet Mounting Holes on the Rear EIA Support Rail
 9. Mounting Rail Lip
- b. Remove the rear hold-down screw. It protrudes from the inside of the rail and prevents you from sliding the controller-drive tray onto the rails.
 - c. Place the mounting rail inside the cabinet, and extend the mounting rail until the flanges on the mounting rail touch the inside of the cabinet.
 - d. Insert one M5 screw through the front of the cabinet, and screw it into the top captured nut in the mounting rail.
 - e. Insert two M5 screws through the rear of the cabinet, and screw them into the captured nuts in the rear flange in the mounting rail.
 - f. Counting up from the bottom of the mounting rail, place the bottom of the screw of the rear bracket in the 8th hole of the cabinet so that the top of the rear bracket is in the 11th hole. The distance between the two holes should be 1U or 4.45 cm (1.75 in).
 - g. Tighten the adjustment screws on the mounting rail.
 - h. Repeat substep a through substep f to install the second mounting rail.
 - i. Insert one M5 screw through the front of the mounting rail. You use this screw to attach the controller-drive tray to the cabinet.

8. Attach the shorter, adjustable size mounting rails to the cabinet.

Figure 41. Short Adjustable Mounting Rail – Left Side

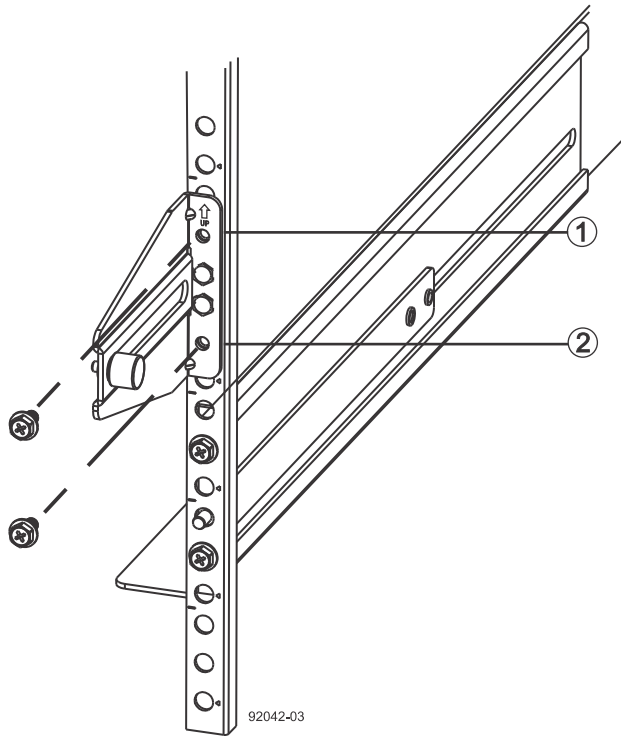


1. Front of the Mounting Rail
2. Rear of the Mounting Rail
3. Rail Fix Bar
4. Two M5 Screws for the Front EIA Support Rail
5. Two Clips for the Front EIA Support Rail
6. Rear Bracket

- a. Make sure that the adjustment screws on the mounting rail are loose but not detached so that the mounting rail can extend or contract as needed.
- b. Place the mounting rail inside the cabinet, and extend the mounting rail until the flanges on the mounting rail touch the inside of the cabinet.

- h. Insert one M5 screw through the front of the mounting rail. This screw attaches the controller-drive tray to the cabinet.

Figure 43. Short Adjustable Mounting Rail with the Rear Bracket Attached to the Cabinet



- 1. Top Cabinet Mounting Hole on the Rear EIA Support Rail
 - 2. Bottom Cabinet Mounting Hole on the Rear EIA Support Rail
9. Remove the bezel from the front of the controller-drive tray.

⚠ WARNING (W10) Risk of bodily injury –



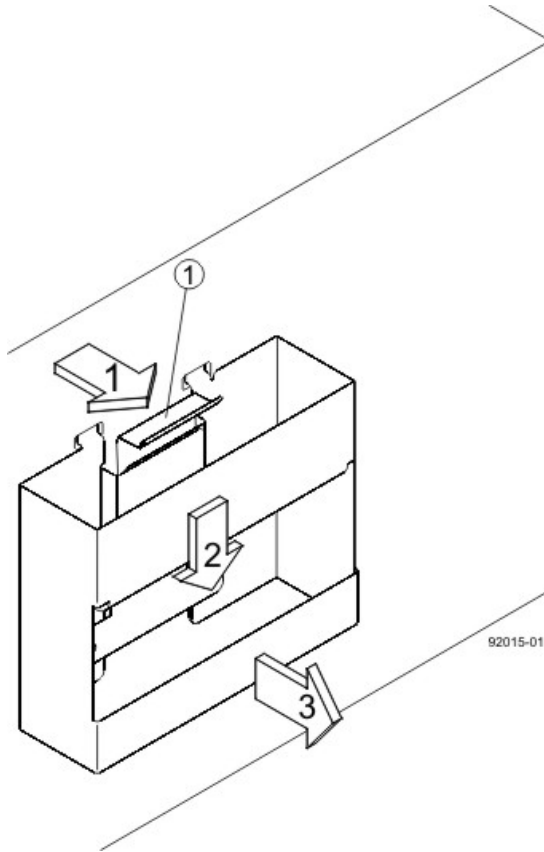
>55 kg (121.3 lbs)

Four or more persons are required to safely lift the component.

- 10. With the help of at least three other persons, slide the rear of the controller-drive tray onto the mounting rails. The controller-drive tray is correctly aligned when the mounting holes on the front flanges of the controller-drive tray align with the mounting holes on the front of the mounting rails.
- 11. After the controller-drive tray is correctly aligned, remove the enclosure lift handles:
 - a. Use your thumb to unlatch and remove the rear controller-drive tray lift handles (two to a side).
 - b. Use the front controller-drive tray lift handles to slide the drive tray all the way into the cabinet.

- c. After the drive tray is securely in the cabinet, use your thumb to unlatch and remove the front controller-drive tray lift handles (two to a side).
- d. Insert the remainder of the tray into the cabinet.

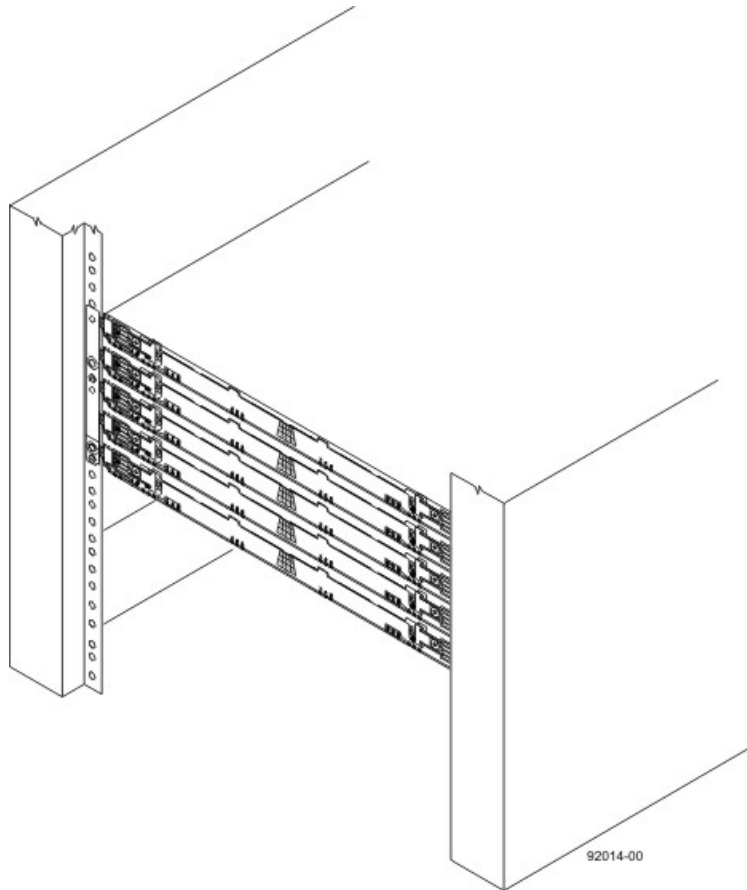
Figure 44. Removing a Controller-Drive Tray Lift Handle from the E2660 Controller-Drive Tray



- 1. Pull the thumb latch away from the controller-drive tray to detach the hook.
 - 2. Shift the handle down to release the other four hooks.
 - 3. Move the handle away from the controller-drive tray.
12. Secure the front of the controller-drive tray to the cabinet. Use the four screws to attach the flange on each side of the front of the controller-drive tray to the mounting rails.
- a. Insert two M5 screws through the bottom holes of a flange on the controller-drive tray so that the screws go through the EIA support rail and engage the bottom captured nuts in the mounting rail. Tighten the screws.
You had attached the second and fourth threaded holes in substep c of step [8](#).
 - b. Repeat substep a for the second flange.
13. Secure the side of the controller-drive tray to the mounting rails.
- a. Tighten the thumbscrew on the rear mounting bracket that you installed in substep e of step [8](#) to secure the controller-drive tray to the mounting rails.
 - b. Repeat substep a for the other side.

NOTE Make sure that each drive drawer in the controller-drive tray is securely latched to ensure proper air flow to the drives.

Figure 45. Controller-Drive Tray Installed in the Cabinet



After you have completed this task, you can install drives in the E2660 controller-drive tray.

Steps to Install – Drives on the E2660 Controller-Drive Tray

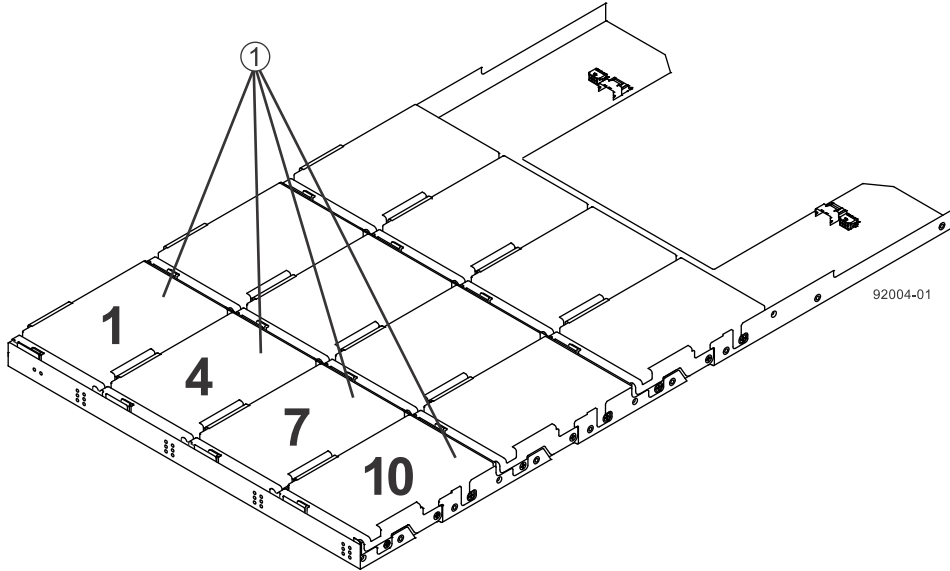
The E2660 controller-drive tray is shipped with the drive drawers installed, but the drives are not installed. Follow the steps in this procedure to install the drives.

ATTENTION Risk of equipment malfunction – To avoid exceeding the functional and environmental limits, install only drives that have been provided or approved by the original manufacturer. Drives might be shipped but not installed. System integrators, resellers, system administrators, or users can install the drives.

The installation order within each drawer is from left to right in rows. Slots 1, 4, 7 and 10 must have a drive installed in these locations to make sure there is sufficient air flow to the drives. To verify these slots, consult the overlay on the front of each of the five drive drawers. Make sure the four drives in each row are adjacent to each other. The long edge of each drive should touch the drive next to it. To maintain a uniform airflow across all drive drawers, the controller-drive tray must be configured with a minimum of 20 drives, with four drives in the front row of each of the five drive drawers.

ATTENTION Risk of equipment malfunction – All 60-drive trays have a limit of five solid state drives (SSDs) per drawer. If you exceed this limit for SSDs in a particular drawer, the power source in the drawer is likely to receive too much current and could fail.

Figure 46. E2660 Drive Drawer with Required Slots Filled

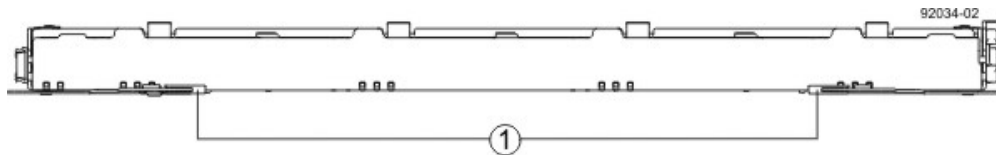


1. E2660 Controller-Drive Tray with Slots 1, 4, 7, and 10

ATTENTION Risk of equipment malfunction – For the E2660 controller-drive tray, you can only replace one canister or drive at a time, as described in the flyer for replacing a failed drive on the E2660 Controller-Drive Tray. Make sure you have the replacement drive in hand before starting the task. Refer to your storage vendor for information about obtaining additional SANtricity Storage Manager documentation.

1. Beginning with the top drawer in the controller-drive tray, release the levers on each side of the drawer by pulling both towards the center.

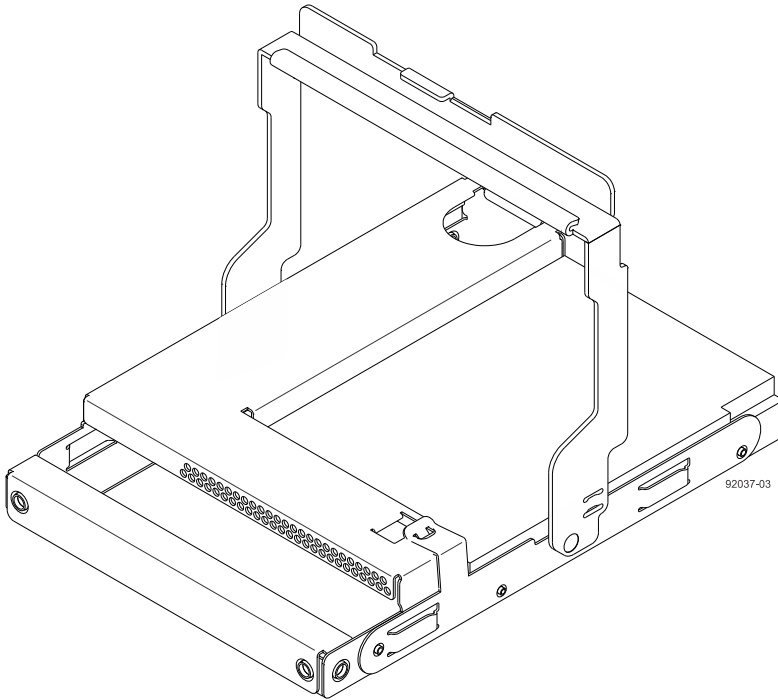
Figure 47. Levers on the Drive Drawer



1. Levers to Release the Drive Drawer
2. Pull on the extended levers to pull the drive drawer out to its full extension without removing it from the controller-drive tray.

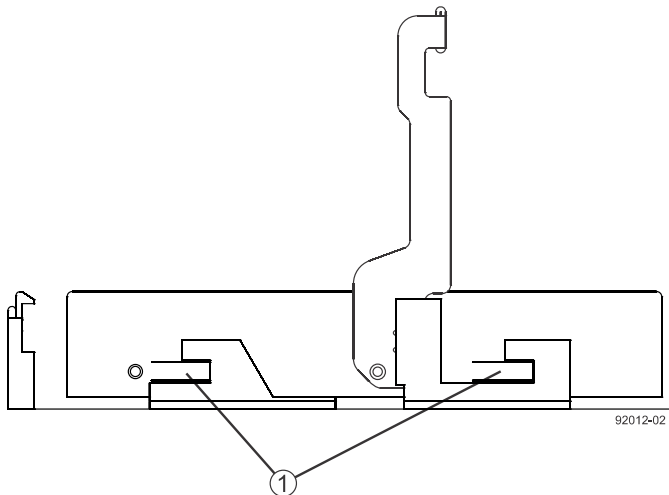
3. Starting with the first drive, raise the drive handle to the vertical position.

Figure 48. Raised Drive Handle



4. Align the two raised buttons on each side over the matching gap in the drive channel on the drawer.

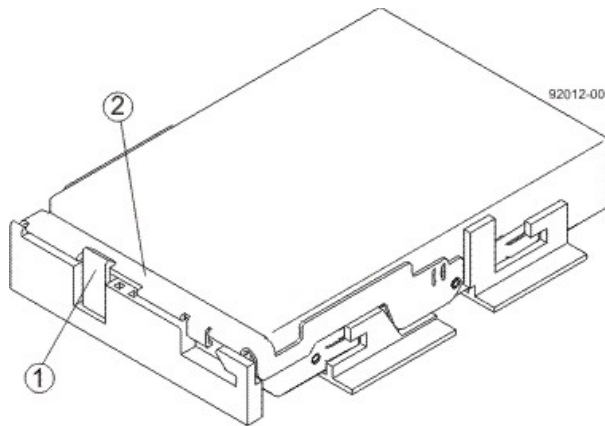
Figure 49. Side View of Drive with Raised Handle



1. Raised Buttons

5. Lower the drive straight down, and then rotate the drive handle down until the drive snaps into place under the drive release lever.

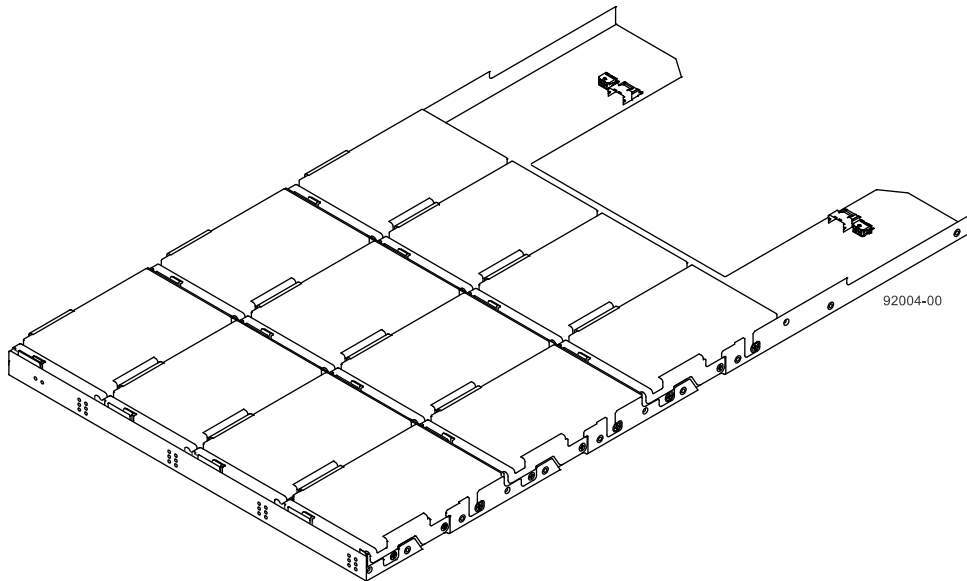
Figure 50. Drive Release Lever Locked by the Drive Handle



1. Drive Release Lever
2. Drive Handle

6. Install the other drives in rows from left to right until the drive drawer is fully populated.

Figure 51. Fully-Populated Drive Drawer



7. Push the drive drawer all the way back into the controller-drive tray, closing the levers on each side of the drive drawer.

ATTENTION Risk of equipment malfunction – Make sure you push both levers to each side so the drive drawer is completely closed. The drive drawer must be completely closed to prevent excess airflow, which has the potential to damage the drives.

8. Continue onto the next drive drawer, repeating step 1 through step 7 for each drive drawer in the configuration.

Step 5 – Connecting the E2600 Controller-Drive Tray to the Hosts

Key Terms

topology

The logical layout of the components of a computer system or network and their interconnections. Topology deals with questions of what components are directly connected to other components from the standpoint of being able to communicate. It does not deal with questions of physical location of components or interconnecting cables. (The Dictionary of Storage Networking Terminology)

direct topology

A topology that does not use a switch.

switch topology

A topology that uses a switch.

Things to Know – Storage Array Configuration Specifications for the E2600 Controller-Drive Tray

Item	Specification
Number of controllers	<ul style="list-style-type: none">■ Two
Number of host connectors per controller	<ul style="list-style-type: none">■ Four SAS host connectors per controller, if the SAS HIC is installed.■ Two base SAS host connectors and four FC host connectors, if the FC HIC is installed.■ Two base SAS host connectors and four 1Gb/sec iSCSI host connectors, if 1Gb/s iSCSI HIC is installed.■ Two base SAS host connectors and two 10Gb/s iSCSI host connectors, if 10Gb/s iSCSI HIC is installed.
Maximum SAS HBA logins per controller	<ul style="list-style-type: none">■ Without HIC: 64■ With HIC: 128
Maximum Fibre Channel logins per controller	<ul style="list-style-type: none">■ 1024
Maximum iSCSI sessions per controller	<ul style="list-style-type: none">■ 1Gb iSCSI HIC : 768■ 10Gb iSCSI HIC: 896
SAS HIC Host Port Link Rate (Gb/sec)	<ul style="list-style-type: none">■ 3, 6

Item	Specification
FC HIC Host Port Link Rate (Gb/s)	<ul style="list-style-type: none"> ■ 2, 4, 8
iSCSI HIC Host Port Link Rate (Gb/s)	<ul style="list-style-type: none"> ■ 1Gb iSCSI HIC : 1 ■ 10Gb iSCSI HIC: 1, 10
Supported Combined Cache and Processor Memory Sizes per controller(GB)	<ul style="list-style-type: none"> ■ 1, 2, 4
Maximum number of drive slots supported	<ul style="list-style-type: none"> ■ DE1600, DE5600, and DE6600: 192 ■ DE6600:180
Maximum number of volumes per storage array	<ul style="list-style-type: none"> ■ 512
Maximum number of storage partitions	<ul style="list-style-type: none"> ■ 128
Maximum number of hosts per storage partition	<ul style="list-style-type: none"> ■ 256
Maximum number of volumes per storage partition	<ul style="list-style-type: none"> ■ 256
Cluster support	<ul style="list-style-type: none"> ■ Microsoft Cluster Server 2008 and Microsoft Cluster Server 2012 operating systems: Windows Hardware Quality Labs (WHQL) testing. ■ Solaris 10 and Solaris 11 (x86) operating systems: Oracle Solaris Cluster Open Storage Program certification ■ SteelEye LifeKeeper (SIOS) Native RH Clustering ■ VMware HA

Things to Know – Host Channels

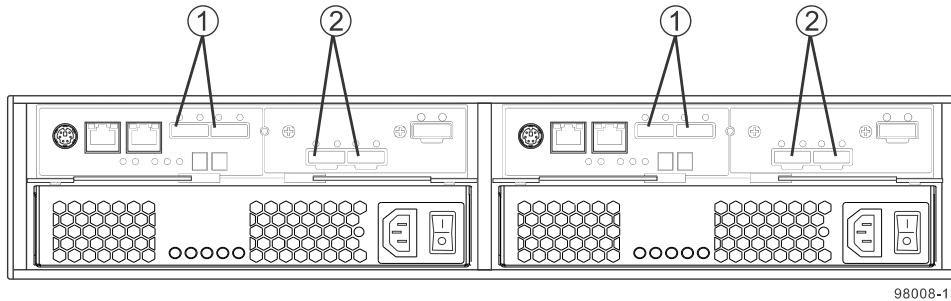
ATTENTION Possible hardware damage –To prevent electrostatic discharge damage to the tray, use proper antistatic protection when you handle tray components.

- Each controller has from two to six host ports.
- Two of the host ports are standard and support 6-Gb/s SAS data rates.
- Two to four of the host ports are optional, and, if present, are located on a host interface card (HIC). The following types of HICs are supported:

NOTE In configurations where a HIC does not exist, the space is covered with a blank faceplate.

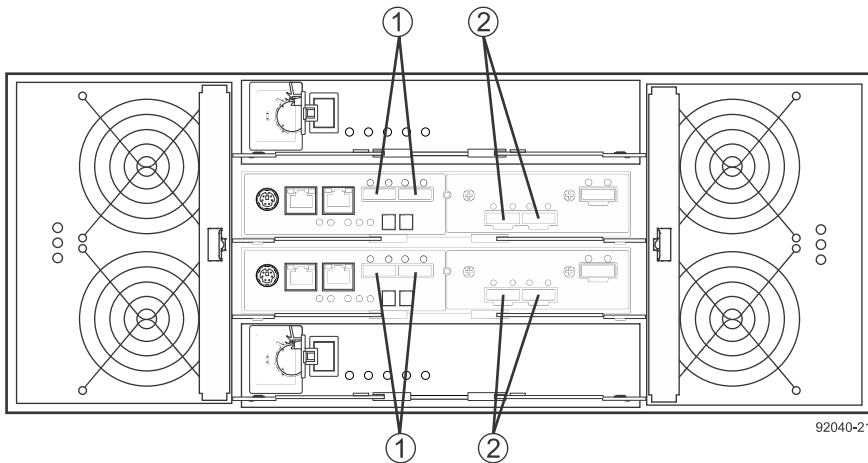
- Two SAS connectors at 6Gb/s
- Four iSCSI connectors at 1Gb/s
- Two iSCSI connectors at 10Gb/s
- Four FC connectors at 8Gb/s

Figure 52. Host Channels on the E2612 and E2624 Controllers – Rear View



1. Standard Host Connectors
2. Host Interface Card (HIC) Connectors (SAS in this Example)

Figure 53. Host Channels on the E2660 Controllers – Rear View



1. Standard Host Connectors
2. Host Interface Card (HIC) Connectors (SAS in this Example)

⚠ WARNING (W03) Risk of exposure to laser radiation –Do not disassemble or remove any part of a Small Form-factor Pluggable (SFP) transceiver because you might be exposed to laser radiation.

Procedure – Connecting Host Cables on a E2600 Controller-Drive Tray

IMPORTANT Make sure that you have installed the HBAs. Refer to the documentation for the HBAs for information about how to install the HBA and how to use the supplied configuration utilities.

The type of HICs (SAS, FC, or iSCSI) must match the type of the host bus adapters (HBAs) or network interface cards (for iSCSI only) to which you connect them.

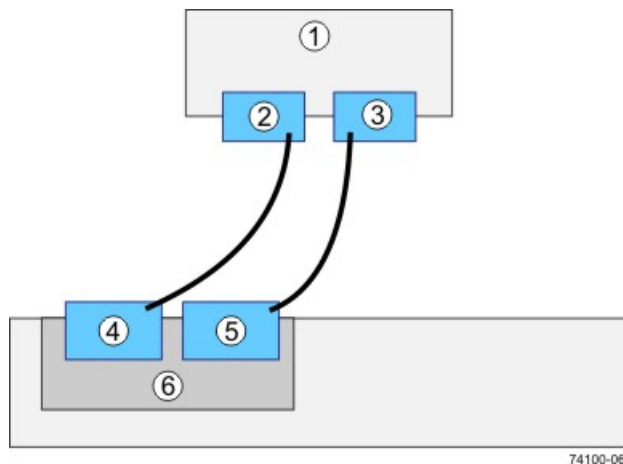
See the examples in the following section for example cabling patterns.

1. Perform one of these actions:
 - **You are using an FC HIC** – Go to [step 2](#).
 - **You are using either a SAS or an iSCSI HIC** – Go to [step 4](#). Connections for iSCSI use copper cables with RJ-45 connectors and do not require SFP transceivers. Connections for SAS use SFF-8088 connectors.
2. Make sure that the appropriate type of SFP transceiver is inserted into the host channel.
3. If a black, plastic plug is in the SFP transceiver, remove it.
4. Perform one of these actions:
 - **You are using either a SAS or an iSCSI HIC** – Starting with the first host channel of each controller, plug one end of the cable into the host channel.
 - **You are using an FC HIC** – Starting with the first host channel of each controller, plug one end of the cable into the SFP transceiver in the host channel.

The cable is either an Ethernet cable with RJ-45 connectors for 1-Gb/s iSCSI connections, an SFF-8088 connector for 6-Gb/s SAS connections, or a fiber-optic cable for FC connections.

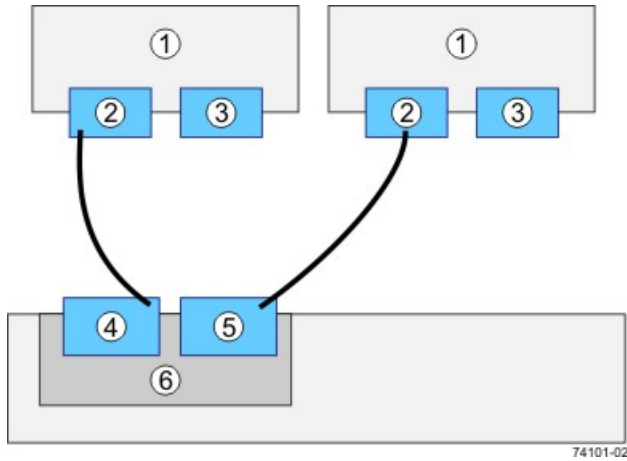
IMPORTANT If Synchronous Mirroring connections are required, do not connect a host to the highest numbered FC host channel as the FC channel is used for the mirrored communications.

Figure 54. Direct Topology – One Host Connected to a Single Controller



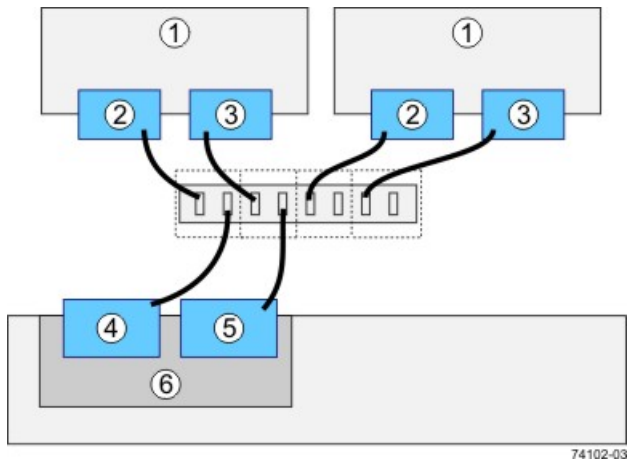
1. Host
2. HBA 1 or NIC 1
3. HBA 2 or NIC 2
4. Host Port 1
5. Host Port 2
6. Controller A

Figure 55. Direct Topology – Two Hosts Connected to a Single Controller



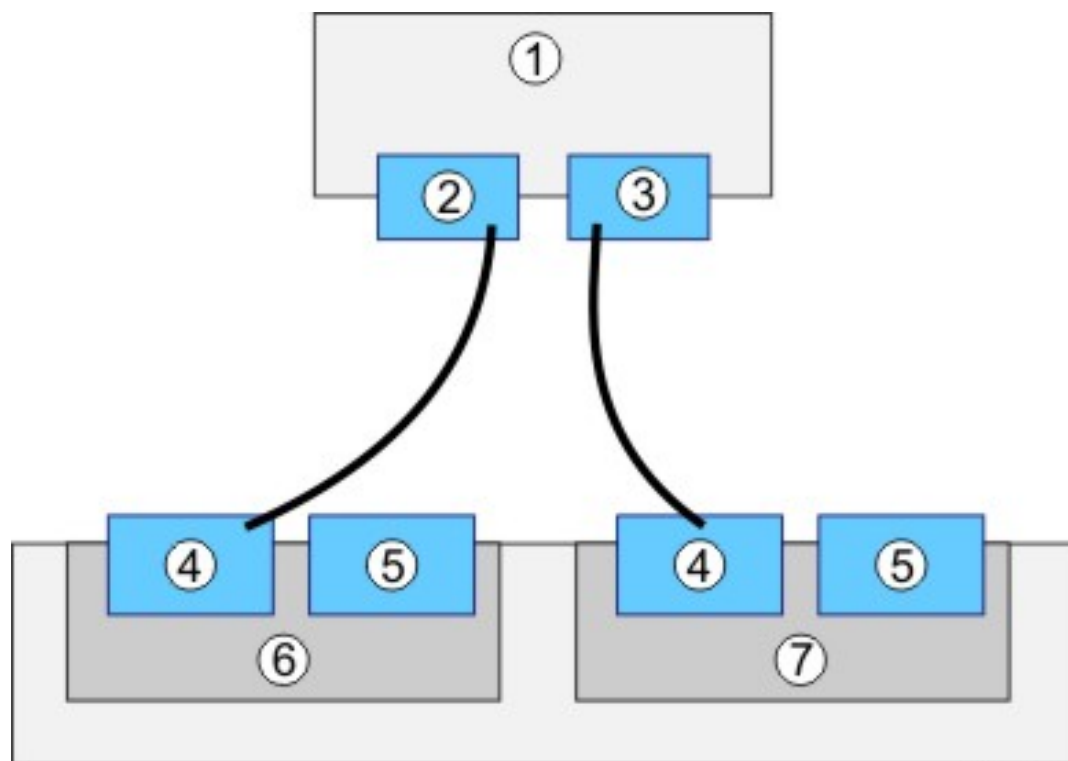
- 1. Host
- 2. HBA 1 or NIC 1
- 3. HBA 2 or NIC 2
- 4. Host Port 1
- 5. Host Port 2
- 6. Controller A

Figure 56. Switch Topology – Two Hosts Connected to a Single Controller Through a Switch



- 1. Host
- 2. HBA 1 or NIC 1
- 3. HBA 2 or NIC 2
- 4. Host Port 1
- 5. Host Port 2
- 6. Controller A

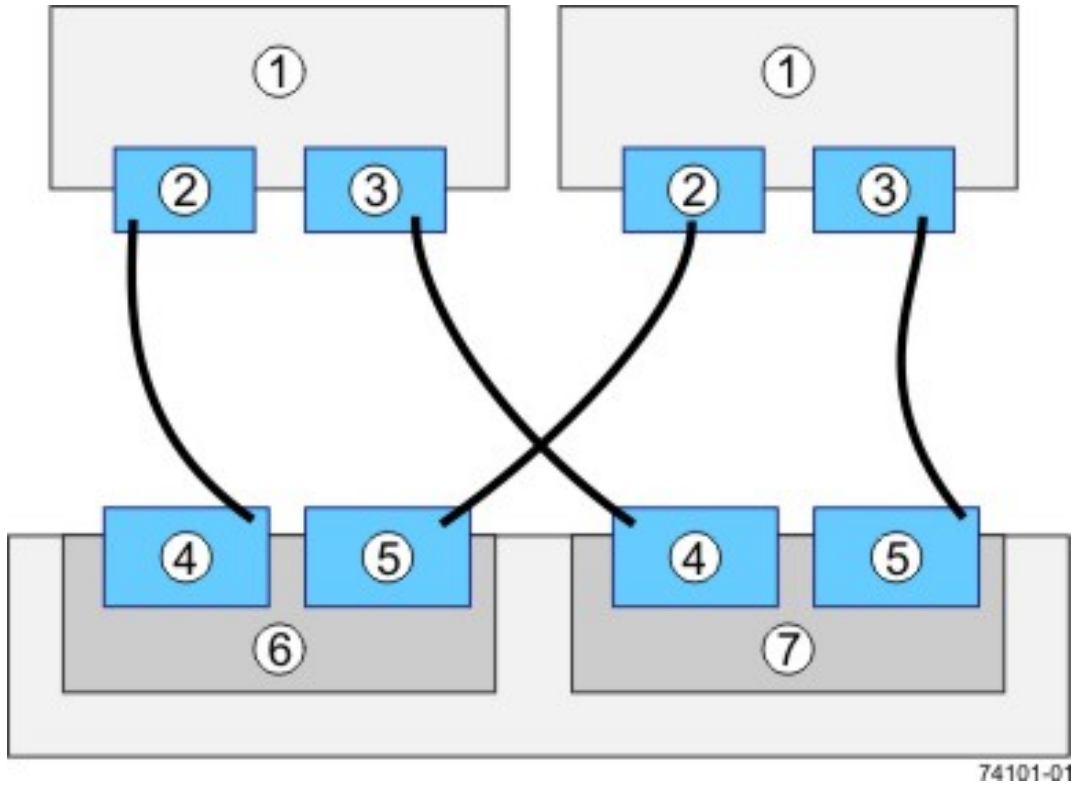
Figure 57. Direct Topology – One Host and a Dual Controller-Drive Tray



74100-01

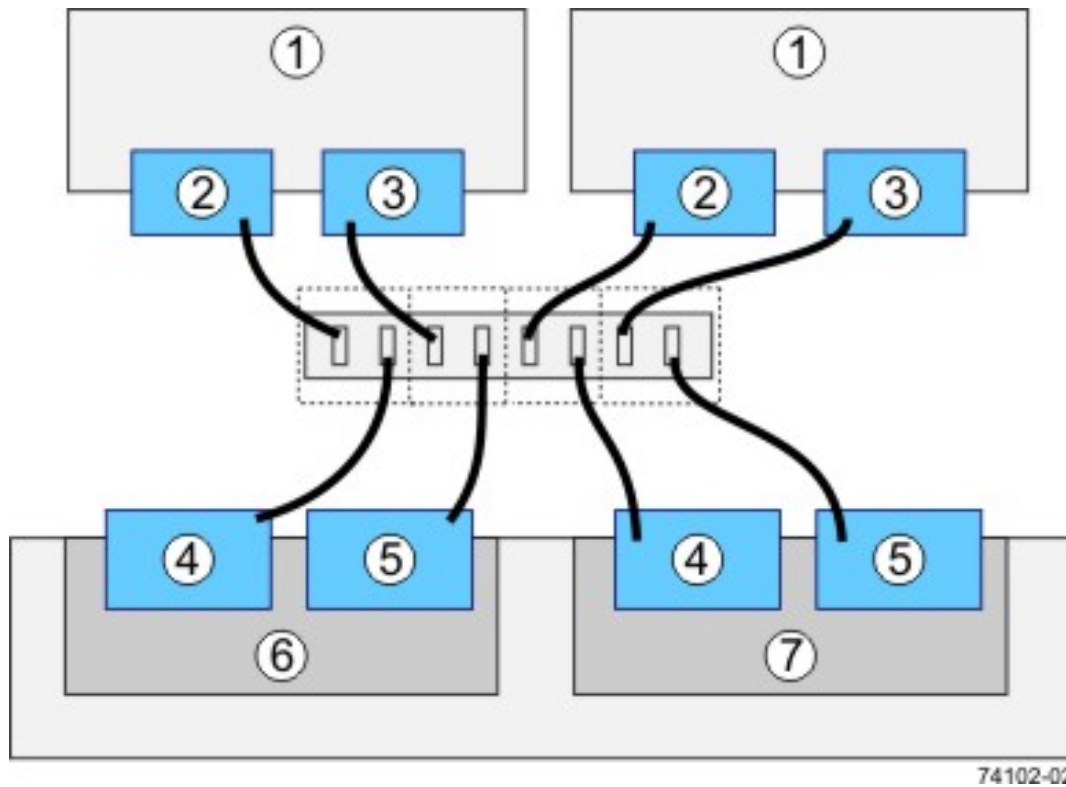
1. Host
2. HBA 1 or NIC 1
3. HBA 2 or NIC 2
4. Host Port 1
5. Host Port 2
6. Controller A
7. Controller B

Figure 58. Direct Topology – Two Hosts and a Dual Controller-Drive Tray for Maximum Redundancy



- 1. Hosts
- 2. HBA 1 or NIC 1
- 3. HBA 2 or NIC 2
- 4. Host Port 1
- 5. Host Port 2
- 6. Controller A
- 7. Controller B

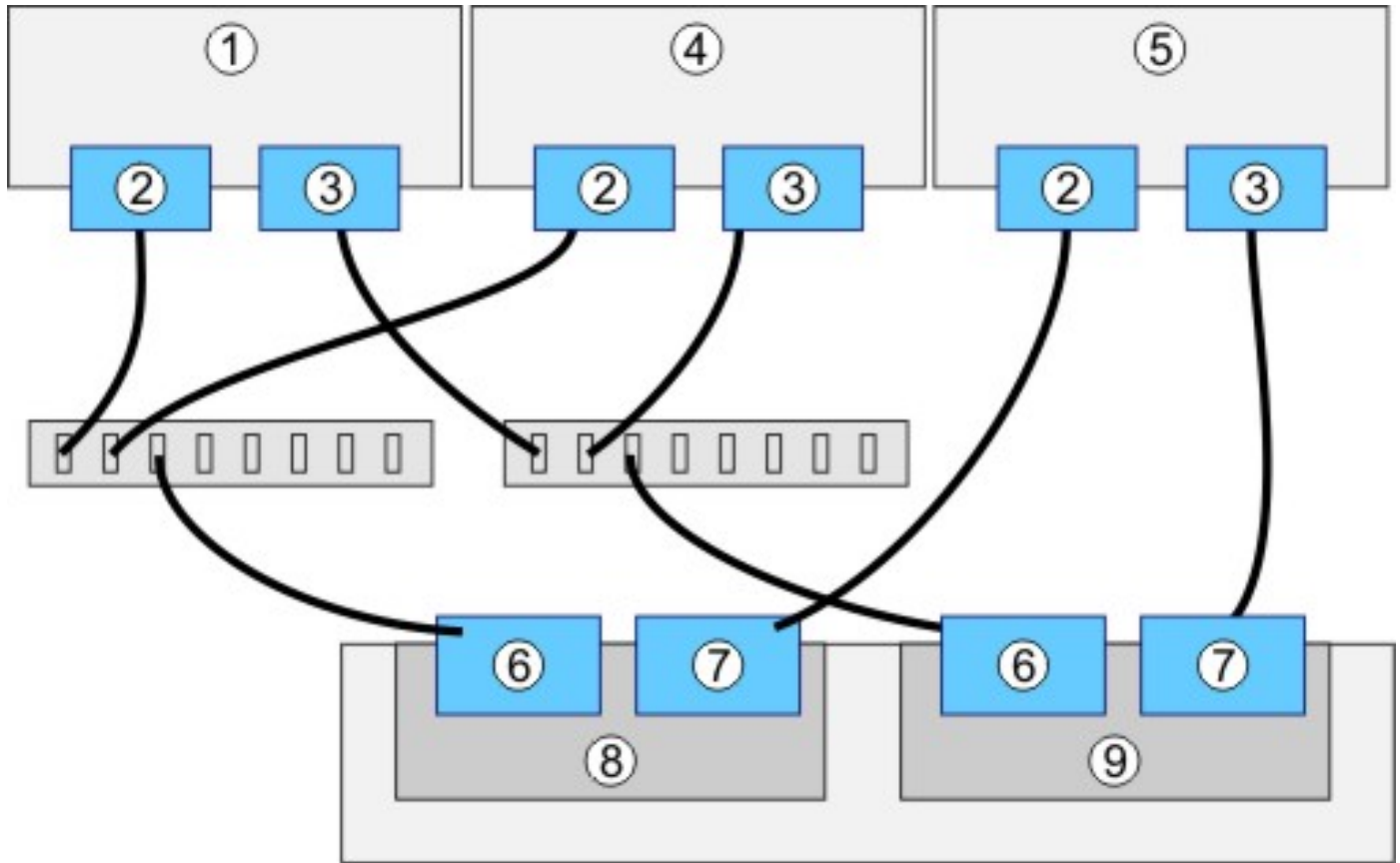
Figure 59. Mixed Topology – Two Hosts and a Dual Controller-Drive Tray



74102-02

1. Hosts
2. HBA 1 or NIC 1
3. HBA 2 or NIC 2
4. Host Port 1
5. Host Port 2
6. Controller A
7. Controller B

Figure 60. Mixed Topology – Three Hosts and a Dual Controller-Drive Tray



74104-01

1. Host 1
2. HBA 1 or NIC 1
3. HBA 2 or NIC 2
4. Host 2
5. Host 3
6. Host Port 1
7. Host Port 2
8. Controller A
9. Controller B

5. Plug the other end of the cable either into an HBA in the host (direct topology) or into a switch (fabric topology).
6. Affix a label to each end of the cable with this information. A label is very important if you need to disconnect cables to service a controller. Include this information on the labels:
 - The host name and the HBA port (for direct topology)
 - The switch name and the port (for fabric topology)
 - The controller ID (for example, controller A)
 - The host channel ID (for example, host channel 1)

Example label abbreviation – Assume that a cable is connected between port 1 in HBA 1 of a host named Engineering and host channel 1 of controller A. A label abbreviation could be as follows.

Heng-HBA1/P1, CtA-Hch1

7. Repeat step 3 through step 6 for each controller and host channel that you intend to use.

Step 6 – Installing the Drive Trays for the E2600 Controller-Drive Tray Configurations

Things to Know – General Installation of Drive Trays with the E2600 Controller-Drive Tray

If you are installing the drive tray in a cabinet with other trays, make sure that the combined power requirements of the drive tray and the other trays do not exceed the power capacity of your cabinet.

- Special site preparation is not required for any of these drive trays beyond what is normally found in a computer lab environment.
- The power supplies meet standard voltage requirements for both domestic and worldwide operation.
- Take these precautions:
 - Install the drive trays in locations within the cabinet that let you evenly distribute the drive trays around the controller-drive tray.
 - Keep as much weight as possible in the bottom half of the cabinet.

Refer to the *Storage System Site Preparation Guide* for important considerations about cabinet installation.

Procedure – Installing the DE1600 Drive Trays and the DE5600 Drive Trays

⚠ WARNING (W08) Risk of bodily injury –



>18 kg (39.7 lbs)

Two persons are required to safely lift the component.

⚠ WARNING (W05) Risk of bodily injury – If the bottom half of the cabinet is empty, do not install components in the top half of the cabinet. If the top half of the cabinet is too heavy for the bottom half, the cabinet might fall and cause bodily injury. Always install a component in the lowest available position in the cabinet.

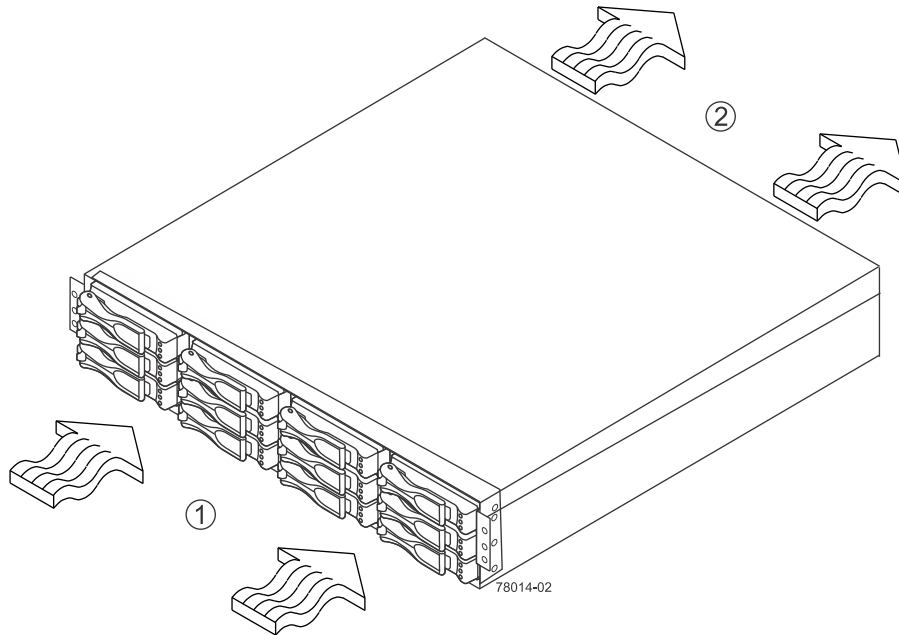
You can install the drive tray into an industry-standard cabinet.

This procedure describes how to install the mounting rails into an industry-standard cabinet.

ATTENTION Possible hardware damage – To prevent electrostatic discharge damage to the tray, use proper antistatic protection when handling tray components.

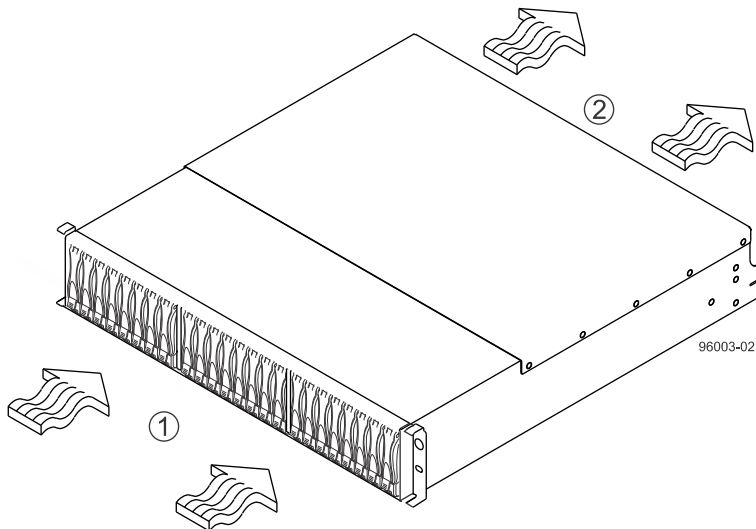
1. Make sure that the cabinet is in the final location. Make sure that you meet the clearance requirements shown in [Figure 61](#) and [Figure 62](#).

Figure 61. DE1600 Drive Tray Airflow and Clearance Requirements



1. 76 cm (30 in.) clearance in front of the cabinet
2. 61 cm (24 in.) clearance behind the cabinet

Figure 62. DE5600 Drive Tray Airflow and Clearance Requirements



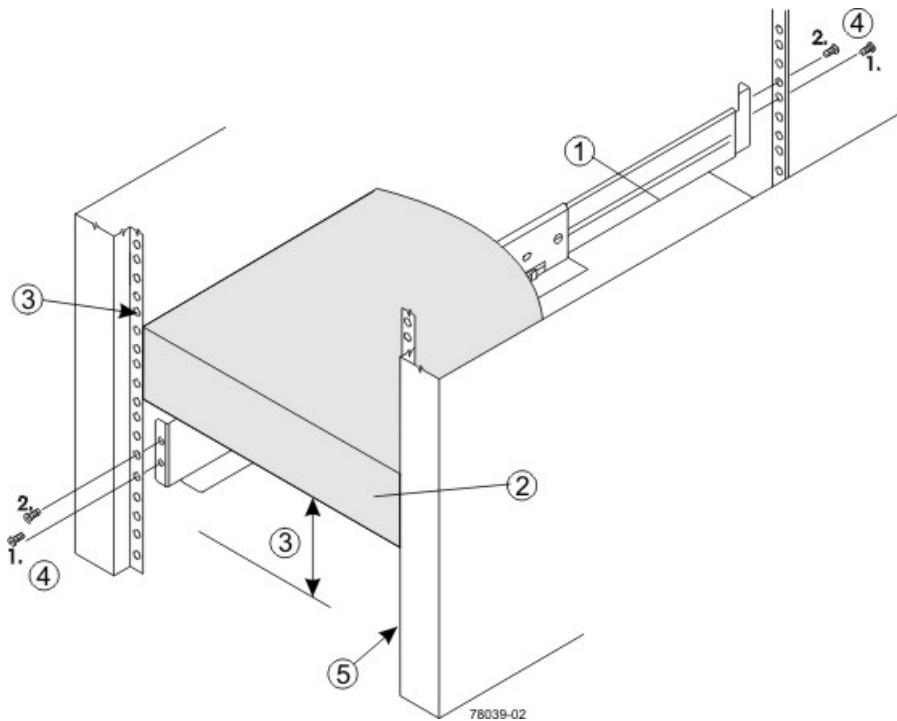
1. 76 cm (30 in.) clearance in front of the cabinet
2. 61 cm (24 in.) clearance behind the cabinet

NOTE Fans pull air through the tray from front to back across the drives.

2. Lower the feet on the cabinet to keep the cabinet from moving.
3. Remove the drive tray and all contents from the shipping carton.

4. Position the mounting rails in the cabinet. For more information, refer to the installation instructions that are included with your mounting rails.

Figure 63. Positioning the Mounting Rails in the Cabinet



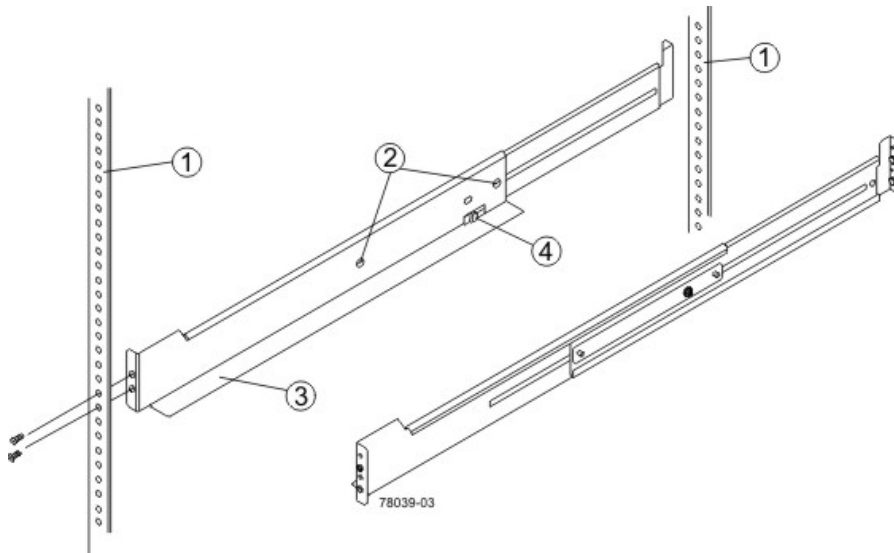
1. Mounting Rail
2. Existing Tray
3. Clearance Above and Below the Existing Tray
4. Screws for Securing the Mounting Rail to the Cabinet (Front and Rear)
5. Industry-standard Cabinet

- If you are installing the mounting rails above an existing tray, position the mounting rails directly above the tray.
- If you are installing the mounting rails below an existing tray, allow either 8.7-cm (3.4-in.) vertical clearance for the DE1600 drive tray or 8.8-cm (3.5-in.) vertical clearance for the DE5600 drive tray.

5. Attach the mounting rails to the cabinet.

- a. Make sure that the adjustment screws on the mounting rail are loose so that the mounting rail can extend or contract as needed.

Figure 64. Attaching the Mounting Rails to the Cabinet

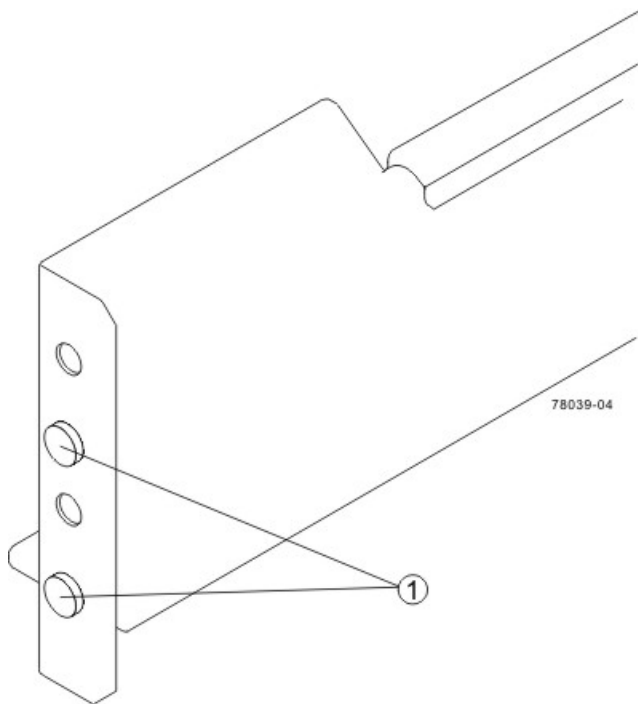


- 1. Cabinet Mounting Holes
 - 2. Adjustment Screws for Locking the Mounting Rail Length
 - 3. Mounting Rails
 - 4. Clip for Securing the Rear of the Drive Tray
- b. Place the mounting rail inside the cabinet, and extend the mounting rail until the flanges on the mounting rail touch the inside of the cabinet.
 - c. Make sure that the alignment spacers on the front flange of the mounting rail fit into the mounting holes in the cabinet.

The front flange of each mounting rail has two alignment spacers. The alignment spacers are designed to fit into the mounting holes in the cabinet. The alignment spacers help position and hold the mounting rail.

NOTE If the cabinet in which you are installing this tray has square holes, there are larger spacers that can be used to mount the rail.

Figure 65. Alignment Spacers on the Mounting Rail

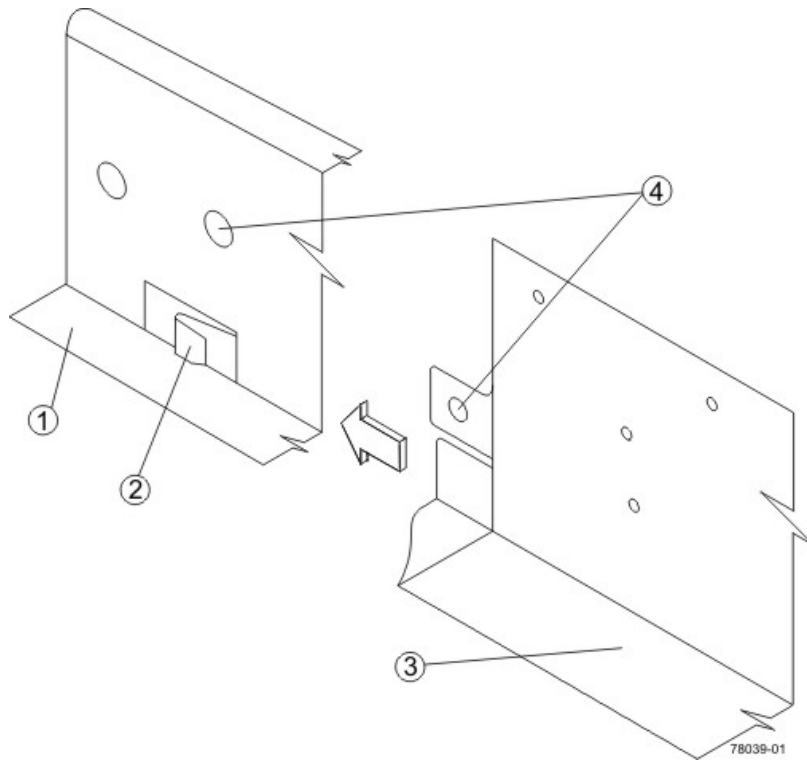


1. Alignment Spacers

- d. Insert one M5 screw through the front of the cabinet and into the top captured nut in the mounting rail. Tighten the screw.
 - e. Insert two M5 screws through the rear of the cabinet and into the captured nuts in the rear flange in the mounting rail. Tighten the screws.
 - f. Tighten the adjustment screws on the mounting rail.
 - g. Repeat substep [a](#) through substep [f](#) to install the second mounting rail.
6. With the help of one other person, slide the rear of the drive tray onto the mounting rails. The rear edge of the drive tray must fit into the clip on the mounting rail. The drive tray is correctly aligned when these conditions are met:
- The mounting holes on the front flanges of the drive tray align with the mounting holes on the front of the mounting rails. See item 4 in the following figure.
 - The rear edge of the drive tray sheet metal fits into the clip on the mounting rail.

- The holes in the drive tray sheet metal for the rear hold-down screws align with the captured nuts in the side of the mounting rails.

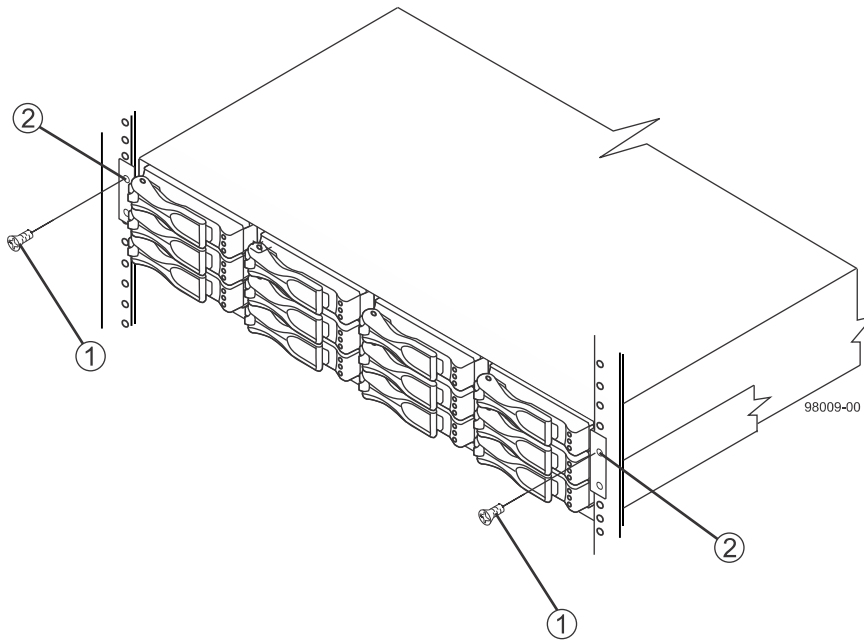
Figure 66. Sliding the Drive Tray into the Clip on the Mounting Rail



1. Mounting Rail
 2. Clip
 3. Partial View of the Drive Tray Rear Sheet Metal
 4. Mounting Holes
7. Secure the front of the drive tray to the cabinet. Use the two screws to attach the flange on each side of the front of the drive tray to the mounting rails.
 - a. Insert one M5 screw through the bottom hole of a flange on the drive tray so that the screw goes through the cabinet rail and engages the bottom captured nut in the mounting rail. Tighten the screw.

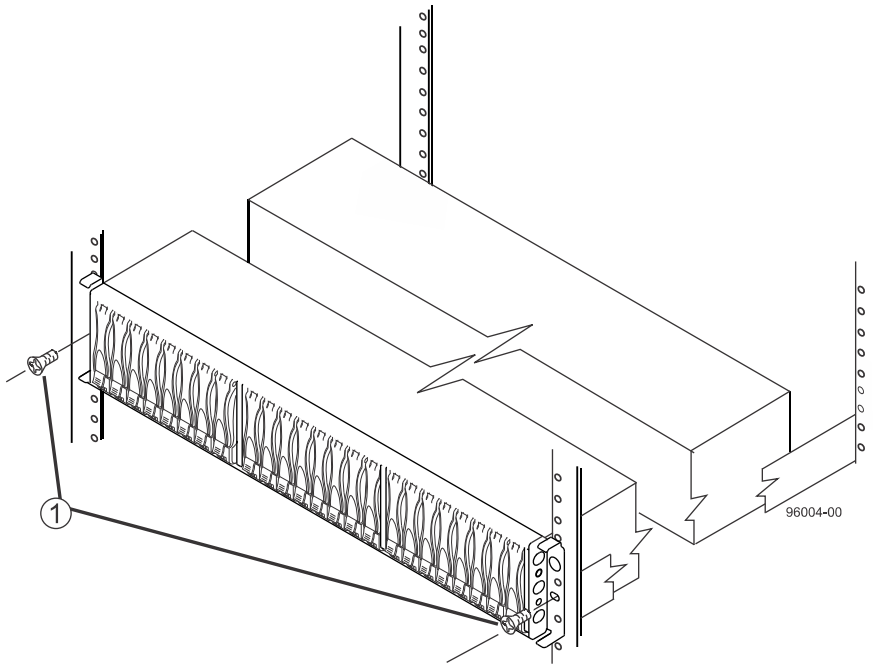
b. Repeat substep [a](#) for the second flange.

Figure 67. Securing the DE1600 Drive Tray to the Cabinet



1. Screw
2. Mounting Hole

Figure 68. Securing the DE5600 Drive Tray to the Cabinet



1. Screw

NOTE The rear of the controller-drive tray contains two controllers. The top of the controller-drive tray is the side with the labels.

8. Secure the side of the drive tray to the mounting rails by performing these substeps:
 - a. Insert one M4 screw through the side sheet metal of the drive tray into the captured nut on the side of the mounting rail. Tighten the screw.
 - b. Repeat substep [a](#) for the other side.
9. Attach the plastic end caps onto the front of the drive tray.
 - a. Put the top of the end cap on the hinge tab that is part of the drive tray mounting flange.
 - b. Gently press on the bottom of the end cap until it snaps into place over the retainer on the bottom of the drive tray mounting flange.

Procedure – Installing Drives in the DE1600 Drive Trays and the DE5600 Drive Trays

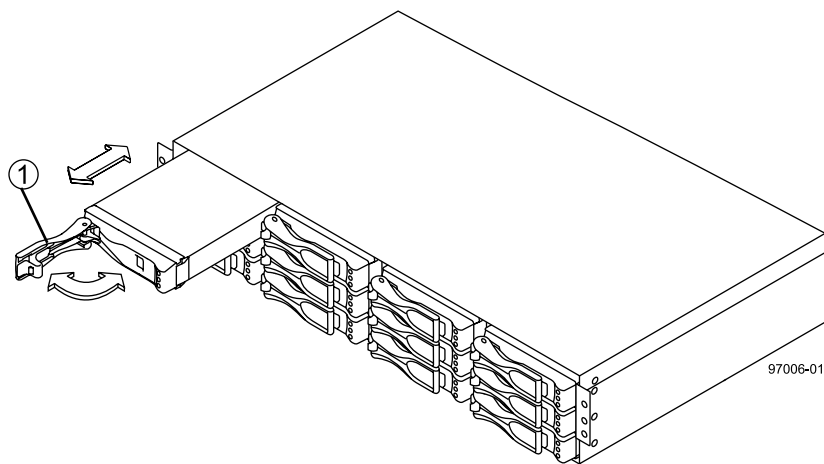
In some situations, the drive tray might be delivered without the drives installed. Follow the steps in this procedure to install the drives.

ATTENTION Risk of equipment malfunction – To avoid exceeding the functional and environmental limits, install only drives that have been provided or approved by NetApp, Inc. Drives might be shipped but not installed. System integrators, resellers, system administrators, or users can install the drives.

NOTE The installation order of the drives is from top to bottom and from left to right for the DE1600 drive tray, and left to right for the DE5600 drive tray. The installation order is important because the drives might already contain configuration information that depends upon the correct sequence of the drives in the tray.

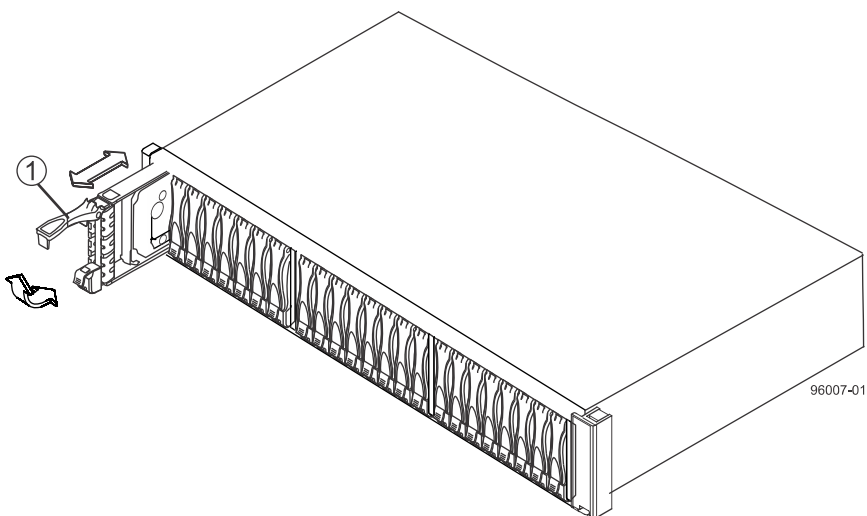
1. Beginning with the first drive slot in the upper-left side of the DE1600 drive tray and the first drive slot on the left side of the DE5600 drive tray, place the drive in the slot guides, and slide the drive all the way into the slot.
2. Push the drive handle to the right (DE1600 drive tray) or down (DE5600 drive tray) to lock the drive securely in place.

Figure 69. Installing a Drive in the DE1600 Drive Tray



1. Drive Handle

Figure 70. Installing a Drive in the DE5600 Drive Tray



1. Drive Handle

NOTE In some applications, the drive handle might have the hinge on the right.

3. Install the second drive beneath the first drive (DE1600 drive tray) or to the right of the first drive (DE5600 drive tray).
4. Install the other drives from top to bottom and then from left to right (DE1600 drive tray) or to the right (DE5600 drive tray).

Things to Know – General Installation of Drive Trays with the E2660 Controller-Drive Tray

If you are installing the drive tray in a cabinet with other trays, make sure that the combined power requirements of the drive tray and the other trays do not exceed the power capacity of your cabinet.

- Special site preparation is not required for any of these drive trays beyond what is normally found in a computer lab environment.
- The power supplies meet standard voltage requirements for both domestic and worldwide operation.
- Take these precautions:
 - Install the drive trays in locations within the cabinet that let you evenly distribute the drive trays around the controller-drive tray.
 - Keep as much weight as possible in the bottom half of the cabinet.

Refer to the *Storage System Site Preparation Guide* for important considerations about cabinet installation.

Procedure – Installing the DE6600 Drive Tray

⚠ WARNING (W10) Risk of bodily injury –



>55 kg (121.3 lbs)

Four or more persons are required to safely lift the component.

ATTENTION Risk of equipment malfunction – To avoid possible equipment damage and ensure safe and efficient servicing of the equipment, install DE6600 drive trays towards the bottom of a cabinet.

⚠ WARNING (W05) Risk of bodily injury – If the bottom half of the cabinet is empty, do not install components in the top half of the cabinet. If the top half of the cabinet is too heavy for the bottom half, the cabinet might fall and cause bodily injury. Always install a component in the lowest available position in the cabinet.

You can install the high-density, 6-Gb SAS SBB 2.0-compliant DE6600 drive tray into an industry-standard cabinet, provided it has a depth of 100 cm (40 in.).

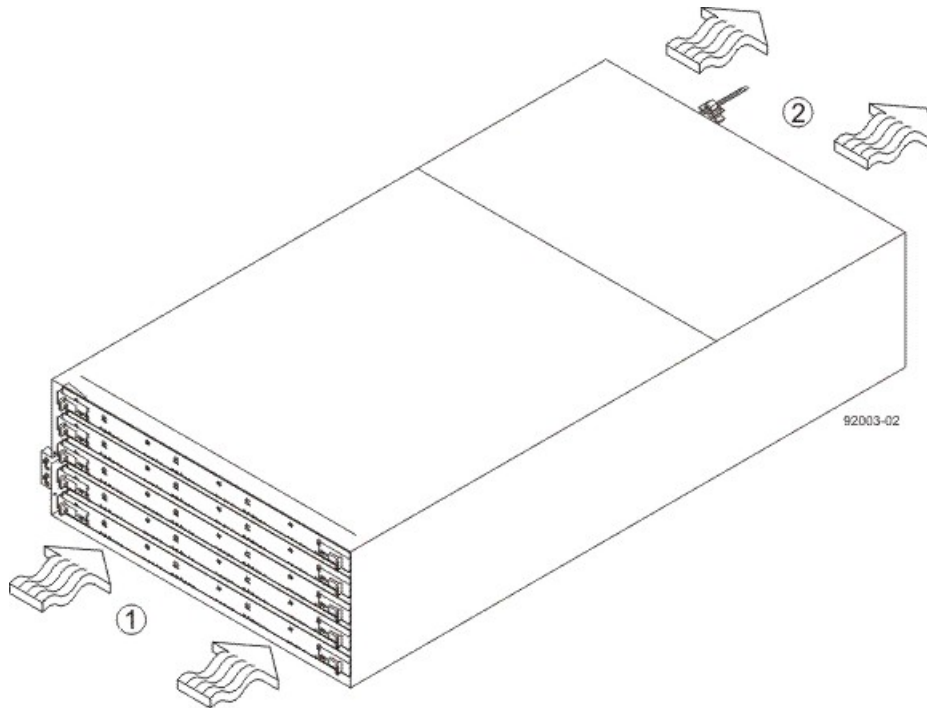
A minimum depth of 76 cm (30 in.) between the front EIA support rails and the rear EIA support rails is required.

This procedure describes how to install the mounting rails into an industry-standard cabinet.

ATTENTION Possible hardware damage – To prevent electrostatic discharge damage to the tray, use proper antistatic protection when handling tray components.

1. Make sure that the cabinet is in the final location. Make sure that you meet the clearance requirements shown in the following figure.

Figure 71. DE6600 Drive Tray Airflow and Clearance Requirements



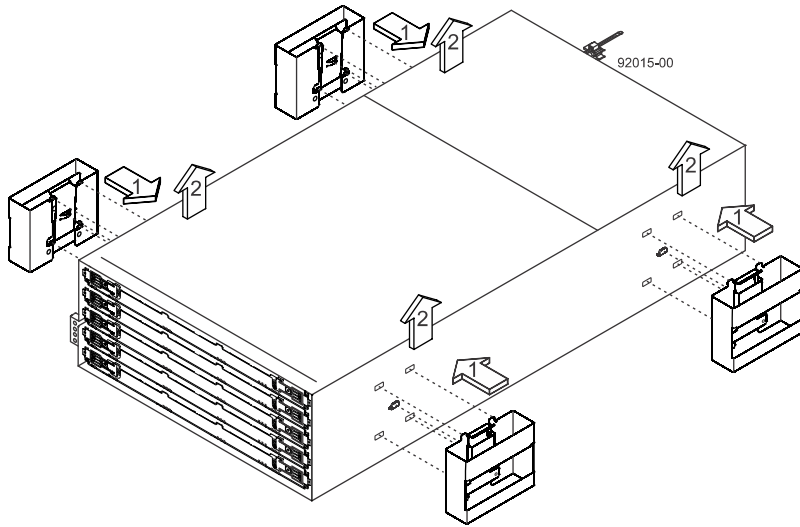
1. 91 cm (36 in.) clearance in front of the cabinet
2. 61 cm (24 in.) clearance behind the cabinet

NOTE Fans pull air through the drive tray from front to back across the drives.

2. Lower the feet on the cabinet to keep the cabinet from moving.
3. Before removing the drive tray and all of the contents from the shipping carton, locate the tray handles and attach them to the drive tray.
 - a. Align the handle just under the thumb latch.

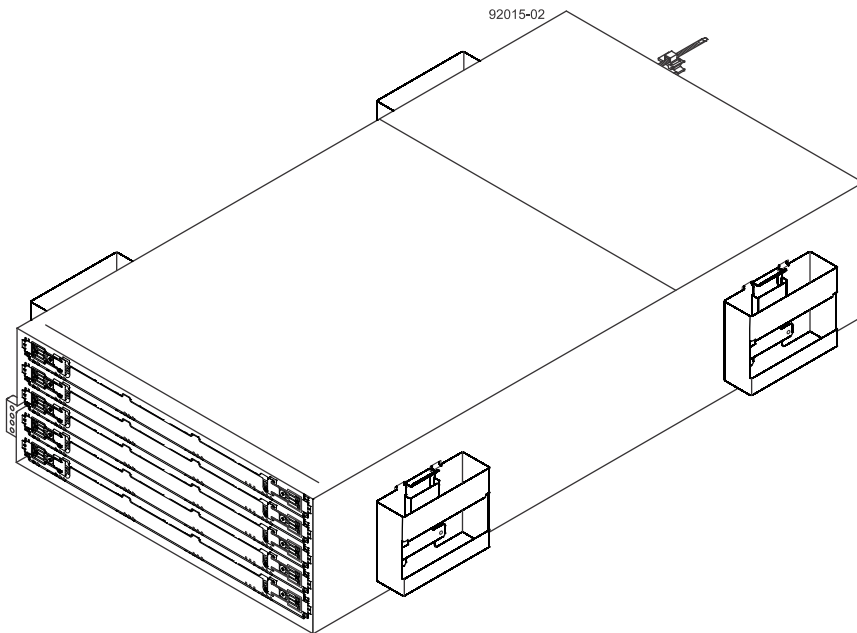
- b. Push the handle up until it clicks in place with the thumb latch.

Figure 72. Attaching the Tray Handles to the Drive Tray



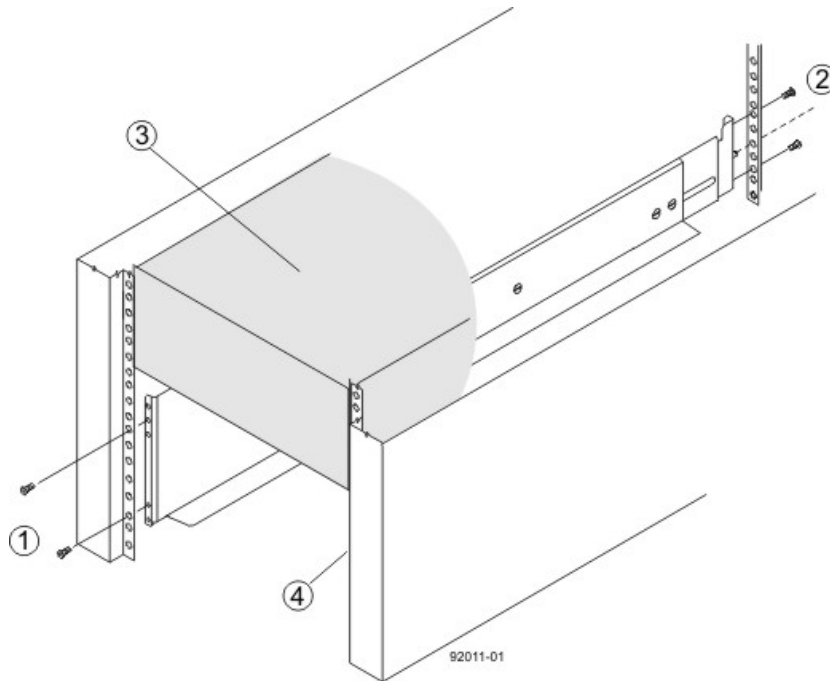
- 4. With the help of at least three other persons, remove the drive tray and all of the contents from the shipping carton, using the four drive tray handles (two to a side) as shown in the following figure. Set the drive tray aside.

Figure 73. DE6600 Drive Tray with Drive Tray Handles (Two on Each Side)



5. Position the mounting rails in the cabinet.

Figure 74. Positioning the Mounting Rails in the Cabinet



1. Screws for Securing the Mounting Rail to the Cabinet (Front)
2. Screws for Securing the Mounting Rail to the Cabinet (Rear)
3. Existing Tray
4. Industry-standard Cabinet

- If you are installing the mounting rails above an existing tray, position the mounting rails directly above the tray.
- If you are installing the mounting rails below an existing tray, allow 17.8 cm (7 in.) vertical clearance for a DE6600 drive tray.

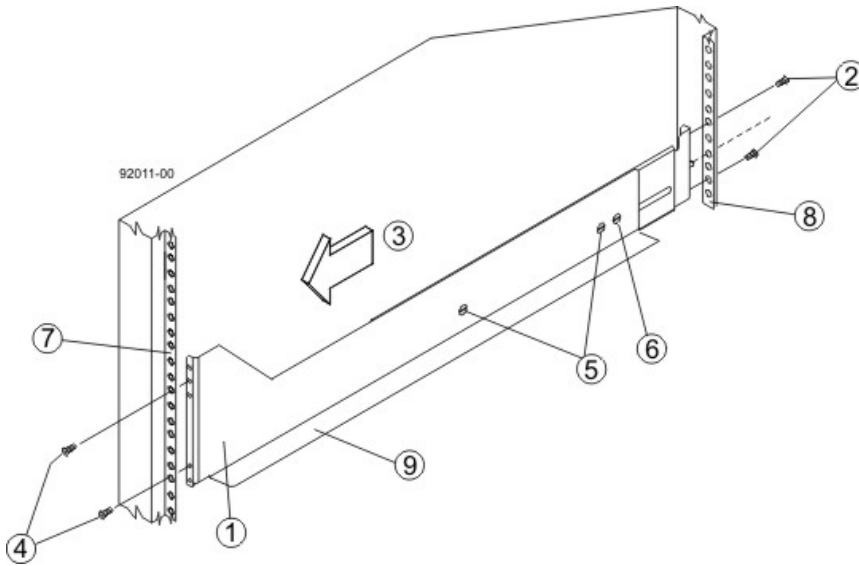
6. To attach the mounting rails to the cabinet, do one of the following:

- If you are using the long fixed-size mounting rails, go to step [7](#).
- If you are using the shorter adjustable mounting rails, go to step [8](#).

7. Attach the long fixed-size mounting rails to the cabinet.

- a. Make sure that the adjustment screws on the mounting rail are loose so that the mounting rail can extend or contract as needed.

Figure 75. Attaching the Long Mounting Rails to the Cabinet



1. Front of the Mounting Rail
2. Two M5 Screws for the Rear EIA Support Rail
3. Front of the Cabinet
4. Two M5 Screws for the Front EIA Support Rail
5. Adjustable Rail Tightening Screws
6. Rear Hold-Down Screw
7. Cabinet Mounting Holes on the Front EIA Support Rail
8. Cabinet Mounting Holes on the Rear EIA Support Rail
9. Mounting Rail Lip

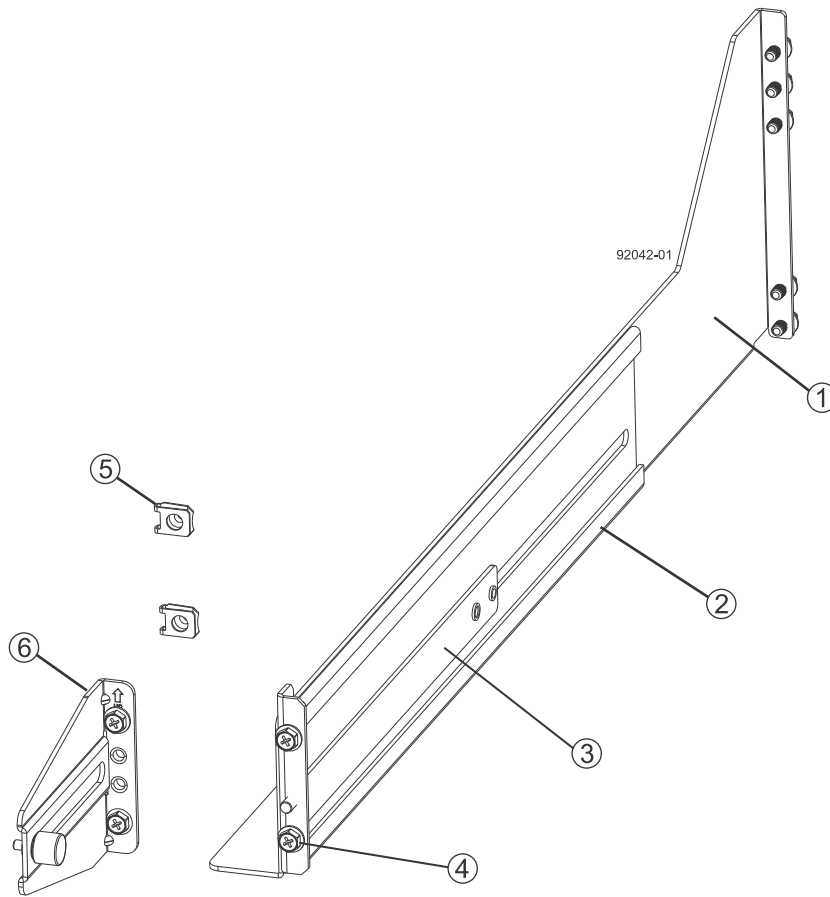
- b. Remove the rear hold-down screw. It protrudes from the inside of the rail and prevents you from sliding the drive tray onto the rails.
- c. Place the mounting rail inside the cabinet, and extend the mounting rail until the flanges on the mounting rail touch the inside of the cabinet.

NOTE If you are mounting the DE6600 drive tray in a cabinet with square holes, use the square hole-to-round hold adapters in the rail kit to align the screws in the holes. The square hole-to-round hold adapters are round washers with shallow shoulders that fit snugly into the square holes in the rack.

- d. Insert one M5 screw through the front of the cabinet, and screw it into the top captured nut in the mounting rail.
- e. Insert two M5 screws through the rear of the cabinet, and screw them into the captured nuts in the rear flange in the mounting rail.
- f. Counting up from the bottom of the mounting rail, place the bottom of the rear bracket in the 8th hole of the cabinet, so that the top of the rear bracket is in the 11th hole. The distance between the two holes should be 1U or 4.45 cm (1.75 in).
- g. Tighten the adjustment screws on the mounting rail.
- h. Repeat substep a through substep g to install the second mounting rail.
- i. Insert one M5 screw through the front of the mounting rail. You use this screw to attach the drive tray to the cabinet.

8. Attach the shorter, adjustable size mounting rails to the cabinet.

Figure 76. Short Adjustable Mounting Rail -- Left Side

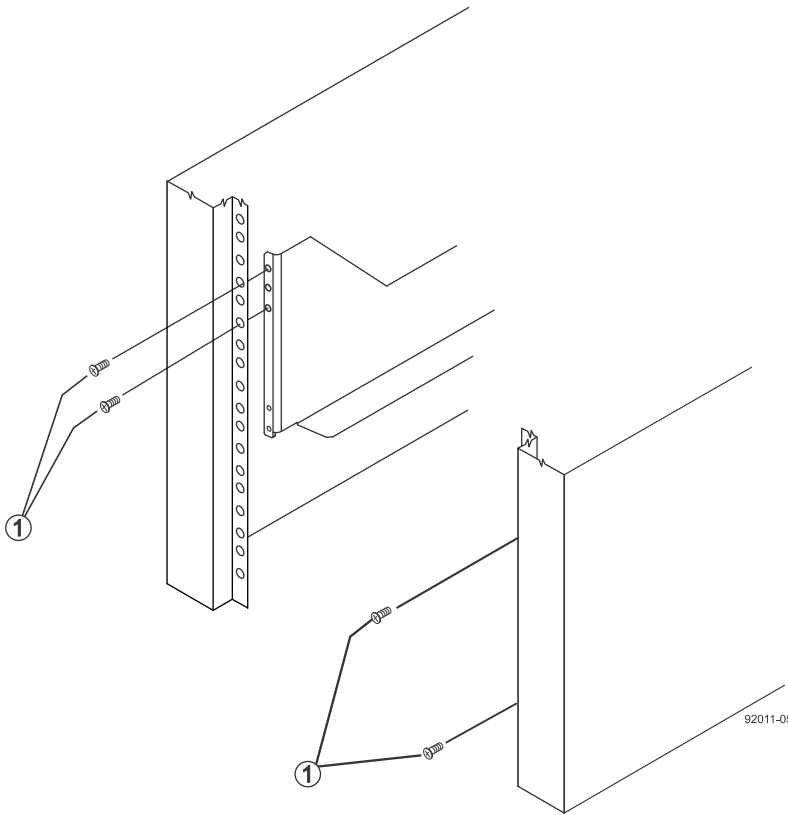


1. Front of the Mounting Rail
2. Rear of the Mounting Rail
3. Rail Fix Bar
4. Two M5 Screws for the Front EIA Support Rail
5. Two Clips for the Front EIA Support Rail
6. Rear Bracket

- a. Make sure that the adjustment screws on the mounting rail are loose so that the mounting rail can extend or contract as needed. The adjustment screws are on the other side of the previous figure.
- b. Place the mounting rail inside the cabinet, and extend the mounting rail until the flanges on the mounting rail touch the inside of the cabinet.

- c. Insert one M5 screw through the front of the cabinet, and screw it into the top captured nut in the mounting rail.

Figure 77. Attaching the Front of the Mounting Rail to the Cabinet

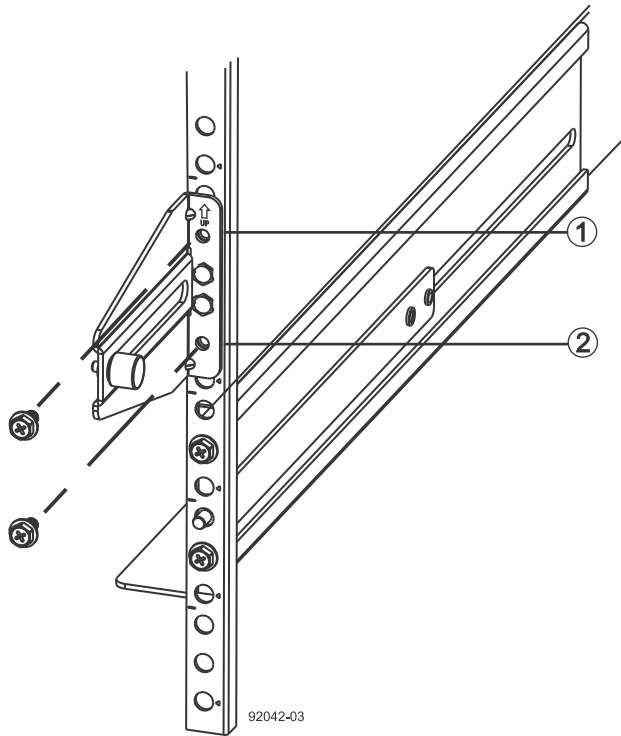


- 1. M5 Screws

- d. Insert two M5 screws through the rear of the cabinet, and screw them into the captured nuts in the rear flange in the mounting rail.
- e. Counting up from the bottom of the mounting rail, place the bottom of the rear bracket in the 8th hole of the cabinet, so that the top of the rear bracket is in the 11th hole. The distance between the two holes should be 1U or 4.45 cm (1.75 in).
- f. Tighten the adjustment screws on the mounting rail.

g. Repeat substep a through substep f to install the second mounting rail.

Figure 78. Short Adjustable Mounting Rail with the Rear Bracket Attached to the Cabinet



- 1. Top Cabinet Mounting Hole on the Rear EIA Support Rail
- 2. Bottom Cabinet Mounting Hole on the Rear EIA Support Rail

9. Remove the bezel from the front of the drive tray.

⚠ WARNING (W10) Risk of bodily injury –



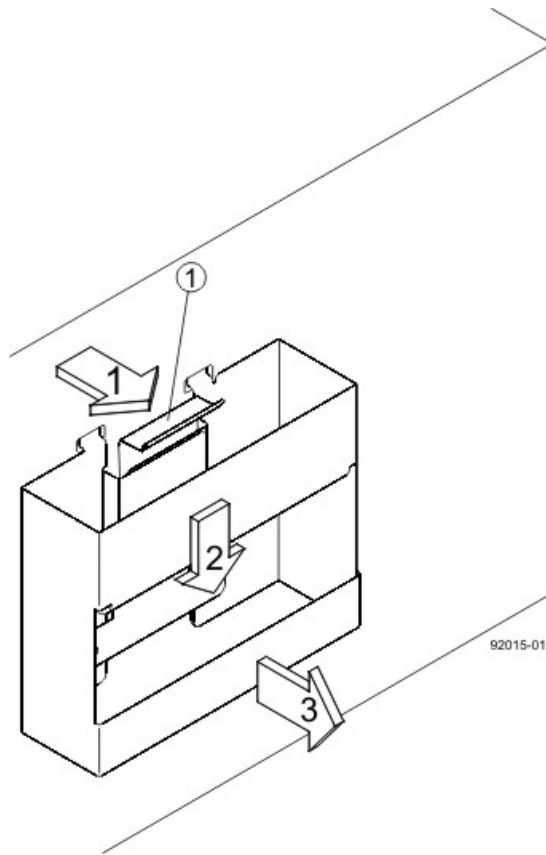
>55 kg (121.3 lbs)

Four or more persons are required to safely lift the component.

- 10. With the help of at least three other persons, slide the rear of the drive tray onto the mounting rails. The drive tray is correctly aligned when the mounting holes on the front flanges of the drive tray align with the mounting holes on the front of the mounting rails.
- 11. After the controller-drive tray is correctly aligned, remove the enclosure lift handles as shown in the following figure:
 - a. Use your thumb to unlatch and remove the rear enclosure lift handles (two to a side).
 - b. Use the front enclosure lift handles to slide the drive tray all the way into the cabinet.

- c. After the drive tray is secure in the cabinet, use your thumb to unlatch and remove the front enclosure lift handles (two to a side).

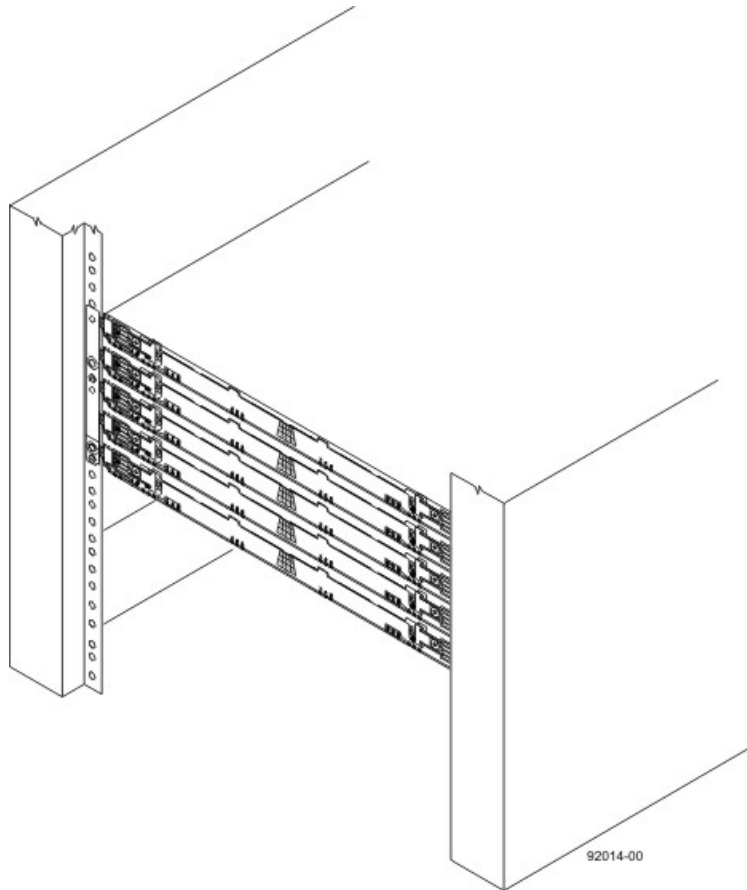
Figure 79. Removing an Enclosure Lift Handle from the Drive Tray



1. Pull the thumb latch away from the drive tray to detach the hook.
 2. Shift the handle down to release the other four hooks.
 3. Move the handle away from the drive tray.
12. Secure the front of the drive tray to the cabinet. Use the four screws to attach the flange on each side of the front of the drive tray to the mounting rails.
- a. Insert two M5 screws through the bottom holes of a flange on the drive tray so that the screws go through the EIA support rail and engage the bottom captured nuts in the mounting rail. Tighten the screws.
You had attached the second and fourth threaded holes in substep c of step [8](#).
 - b. Repeat substep a for the second flange.
13. Secure the side of the drive tray to the mounting rails.
- a. Tighten the thumbscrew on the rear mounting bracket that you installed in substep e of step [8](#) to secure the drive tray to the mounting rails.
 - b. Repeat substep a for the other side.

NOTE Make sure that each drive drawer in the drive tray is securely fastened to ensure proper air flow to the drives.

Figure 80. Drive Tray Installed in the Cabinet



14. Continue with [Procedure – Installing Drives in the DE6600 Drive Tray](#).

Procedure – Installing Drives in the DE6600 Drive Tray

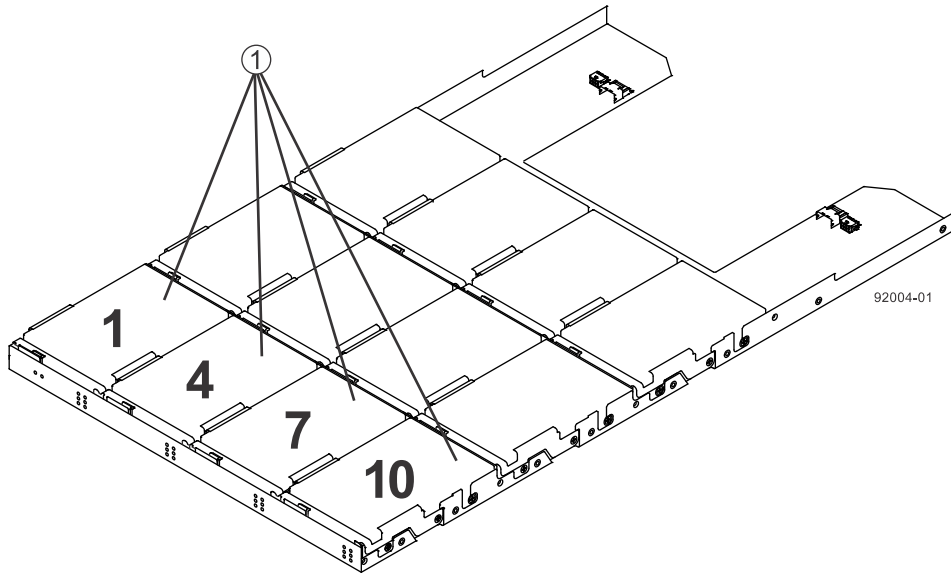
The DE6600 drive tray is shipped with the drive drawers installed, but the drives are not installed. Follow the steps in this procedure to install the drives.

ATTENTION Risk of equipment malfunction – To avoid exceeding the functional and environmental limits, install only drives that have been provided or approved by NetApp, Inc. Drives might be shipped but not installed. System integrators, resellers, system administrators, or users can install the drives.

The installation order of the drives within each drawer is from left to right in rows. Slots 1, 4, 7, and 10 must have a drive or a drive blank installed in these locations to make sure there is sufficient air flow to the drives. To verify these slots, consult the overlay on the front of each of the five drive drawers. Make sure the four drives in each row are adjacent to each other. The long edge of each drive should touch the drive next to it. To maintain a uniform airflow across all drive drawers, the drive tray must be configured with a minimum of 20 drives, with four drives in the front row of each of the five drive drawers.

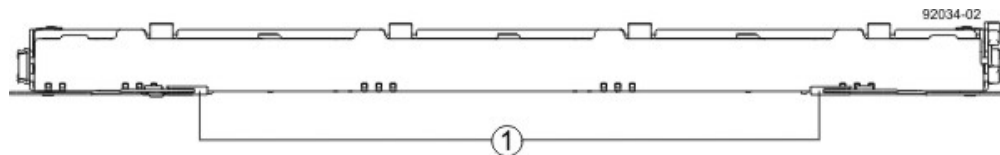
ATTENTION Risk of equipment malfunction – All DE6600 drive trays have a limit of five solid state drives (SSDs) per drawer. If you exceed this limit for SSDs in a particular drawer, the power source in the drawer could fail.

Figure 81. DE6600 Drive Drawer with Required Slots Filled



1. DE6600 Drive Tray with Slots 1, 4, 7, and 10
1. Beginning with the top drawer in the drive tray, release the levers on each side of the drawer by pulling both towards the center.

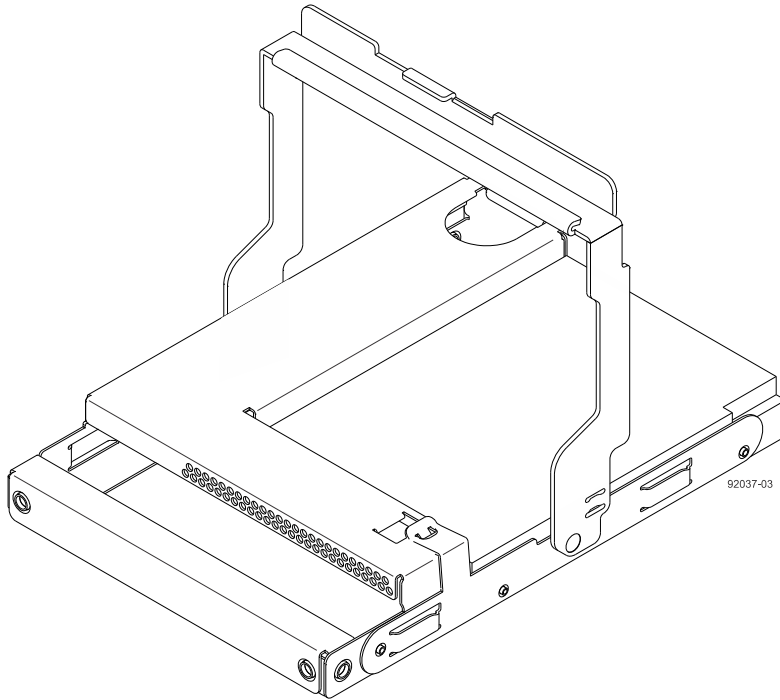
Figure 82. Levers on the Drive Drawer



1. Levers to Release the Drive Drawer
2. Pull on the extended levers to pull the drive drawer out to its full extension without removing it from the drive tray.

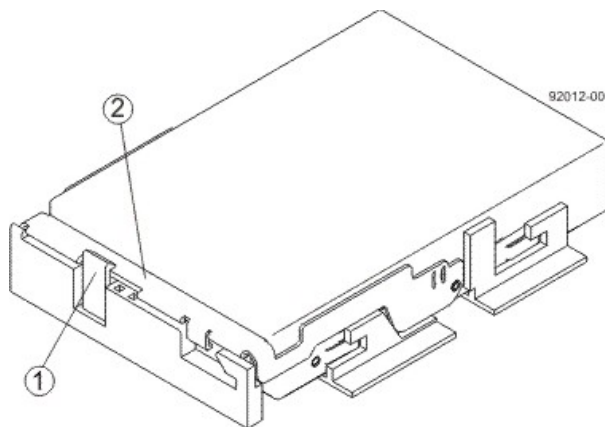
- Starting with the first drive, raise the drive handle to the vertical position.

Figure 83. Raised Drive Handle



- Align the two raised buttons on each side over the matching gap in the drive channel on the drawer.
- Lower the drive straight down, and then rotate the drive handle down until the drive snaps into place under the drive release lever as shown in the following figure.

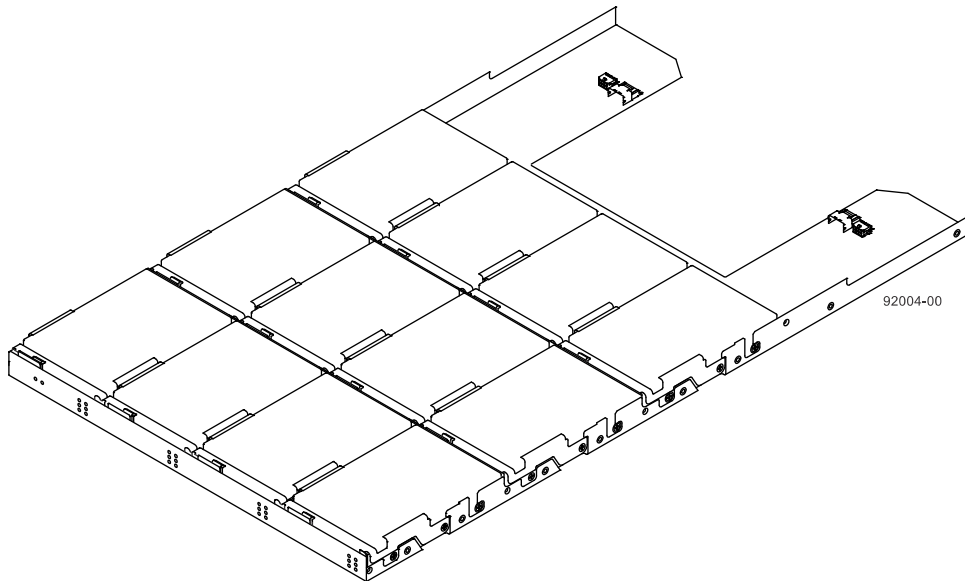
Figure 84. Drive Release Lever Locked by the Drive Handle



- Drive Release Lever
- Drive Handle

6. Install the other drives in rows from left to right until the drive drawer contains at least four drives in the front row of each drawer.

Figure 85. Fully-Populated Drive Drawer



7. Push the drive drawer all the way back into the drive tray, closing the levers on each side of the drive drawer.

ATTENTION Risk of equipment malfunction – Make sure you push both levers to each side so the drive drawer is completely closed. The drive drawer must be completely closed to prevent excess airflow, which has the potential to damage the drives.

8. Continue onto the next drive drawer, repeating step [1](#) through step [7](#) for each drive drawer in the configuration.

Procedure – Connecting the Power Cords

1. Make sure that the circuit breakers in the cabinet are turned off.
2. Make sure that both of the Power switches on the drive trays are turned off.
3. Connect the primary power cords from the cabinet to the external power source.

Things to Know – Connecting the Power Cords

- For each AC power connector on the drive tray, make sure that you use a separate power source in the cabinet. Connecting to independent power sources maintains power redundancy.
- To ensure proper cooling and assure availability, the drive tray always uses two power supplies.
- You can use the power cords shipped with the drive tray with typical outlets used in the destination country, such as a wall receptacle or an uninterruptible power supply (UPS). These power cords, however, are not intended for use in most EIA-compliant cabinets.

NOTE Make sure that you do not turn on the power to the drive tray until this installation guide instructs you to do so.

Step 7 – Connecting the E2600 Controller-Drive Tray to the Drive Trays

Key Terms

drive channel

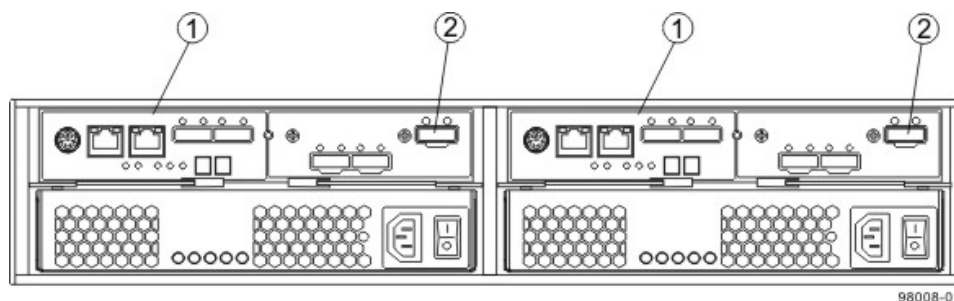
The path for the transfer of data between the controllers and the drives in the storage array.

Things to Know – E2600 Controller-Drive Tray

NOTE On the E2600 controller-drive tray, each controller has a pair of levers with handles for removing the controller from the controller-drive tray. One of these handles on each controller is located next to a host connector. The close spacing between the handle and the host connector might make it difficult to remove a cable that is attached to the host connector. If this problem occurs, use a flat-blade screwdriver to push in the release component on the cable connector.

- The E2600 controller-drive tray supports both the DE1600 drive tray and the DE5600 drive tray for expansion.
- The maximum number of drive slots in the storage array is 192, including the 12 or 24 drive slots in the controller-drive tray. Exceeding 192 drive slots makes the storage array invalid. The controllers cannot perform operations that modify the configuration, such as creating new volumes.
- Each controller has one dual-ported SAS expansion connector to connect to the drive trays.

Figure 86. Drive Channel Ports on the E2600 Controller-Drive Tray–Rear View



1. Controller Canister
2. SAS Expansion Connector

NOTE To maintain data access in the event of the failure of a controller, an ESM, or a drive channel, you must connect a drive tray or a string of drive trays to both drive channels on a redundant path pair.

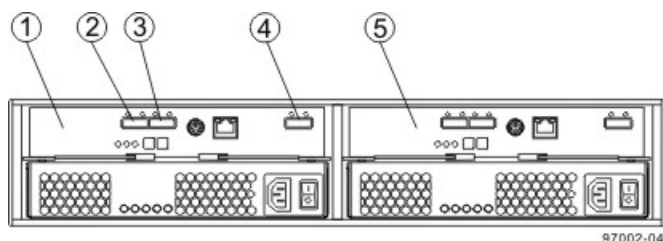
ATTENTION Potential damage to equipment (Network Telecommunications Equipment (NEBS) Ethernet cable installations only) –The intra-building port(s) (Ethernet maintenance ports) of this equipment is suitable for connection to intra-building or unexposed wiring or cabling only. The intra-building port(s) of this equipment must be metallically connected to interfaces that connect to the Outside Plant (OSP) or its wiring. These interfaces are

designed for use as intra-building interfaces only (Type 2 or Type 4 ports as described in GR-1089-CORE) and require isolation from the exposed OSP cabling. The addition of Primary Protectors is not sufficient protection in order to connect these interfaces metallurgically to OSP wiring. The cable shall be shielded Twisted Pair (STP) and must be grounded at both ends to meet the intra-building lightning requirements from section 4.6.9.2 of GR-1089-CORE, Issue #5.

Things to Know – Drive Trays with the E2612 or the E2624 Controller-Drive Tray

- Each DE1600 drive tray can contain a maximum of twelve 8.89-cm (3.5-in.) drives.
- Each DE5600 drive tray can contain a maximum of twenty-four 6.35-cm (2.5-in.) drives.
- The ESMs on the DE1600 drive tray and the DE5600 drive tray contain two sets of In connectors and one set of Out connectors.

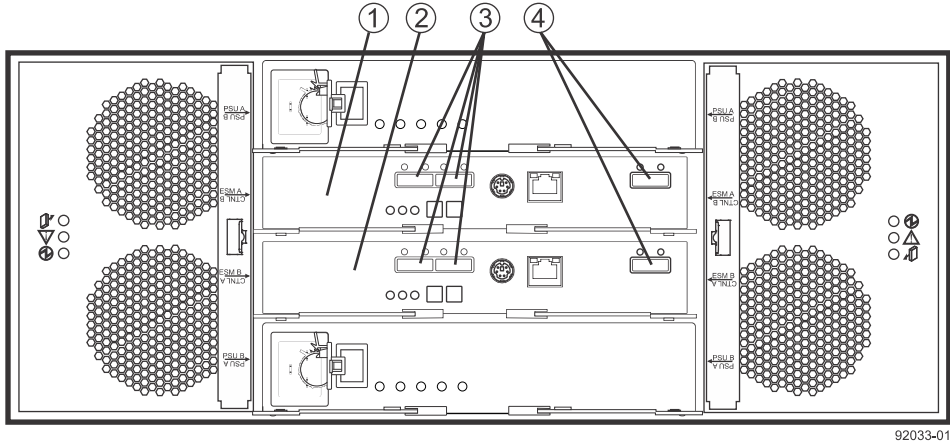
Figure 87. DE1600 Drive Tray and DE5600 Drive Tray – Rear View



1. ESM A
2. SAS Connector 1 (In)
3. SAS Connector 2 (In)
4. Expansion Connector (Out)
5. ESM B

Each DE6600 drive tray can contain a maximum of sixty 8.89-cm (3.5-in.) drives housed with five drawers of 12 drives each.

Figure 88. DE6600 Drive Tray – Rear View



1. ESM A
2. ESM B
3. SAS IN Connectors
4. Expansion Connectors

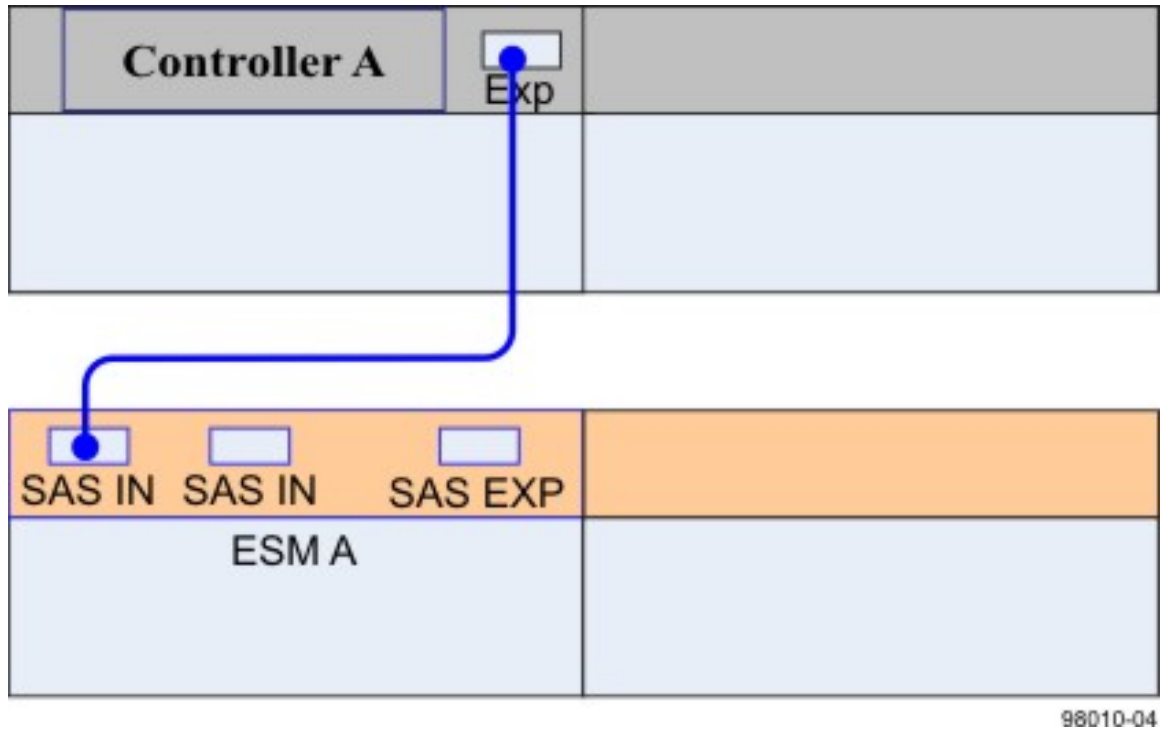
Things to Know – Drive Tray Cabling Configurations – Simplex System

The following figure shows an example of cable configurations from the simplex E2612 or E2624 controller-drive tray to either a DE1600 drive tray or a DE5600 drive tray. Use this example as a guide to connect cables in your storage array.

You can intermix the DE1600, the DE5600, and DE6600 drive trays with the E2612 or the E2624 controller-drive tray up to a maximum of 192 drive slots in a storage array.

IMPORTANT Configurations for connecting cables in a simplex system do not provide for tray loss protection. Loss of a drive tray that has a second drive tray connected to it means that you cannot access the second drive tray.

Figure 89. Controller-Drive Tray Above the Drive Tray



Things to Know – Drive Tray Cabling Configurations – Duplex System

The figures in this topic show examples of cable configurations from the controller-drive tray to the drive trays. Use these examples as guides to connect cables in your storage array.

You can intermix the DE1600, the DE5600, and DE6600 drive trays with the E2612 or the E2624 controller-drive tray up to a maximum of 192 drive slots in a storage array.

The configuration shown in the fourth image in this topic provides an example of tray loss protection. With tray loss protection, if one drive tray cannot be accessed, you still have access to the remaining drive trays.

Figure 90. Controller-Drive Tray Above the Drive Tray

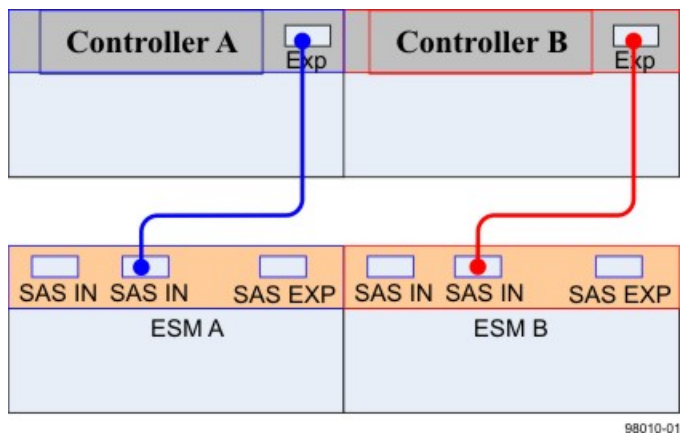


Figure 91. Controller-Drive Tray Between Two Drive Trays

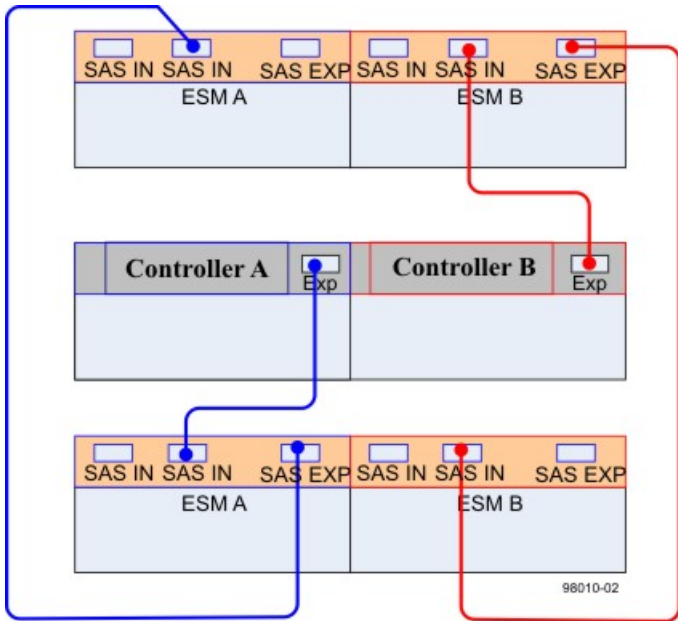


Figure 92. Controller-Drive Tray with Three Drive Trays

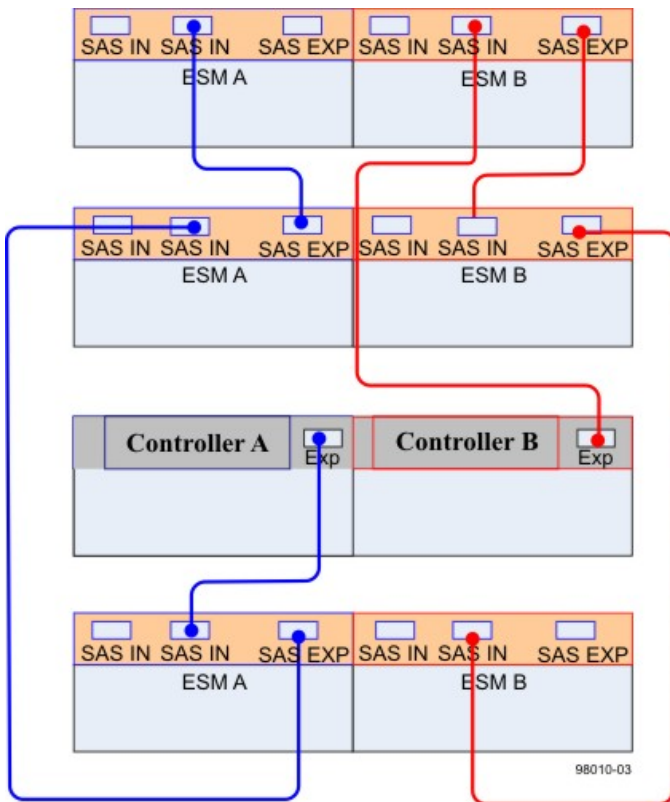
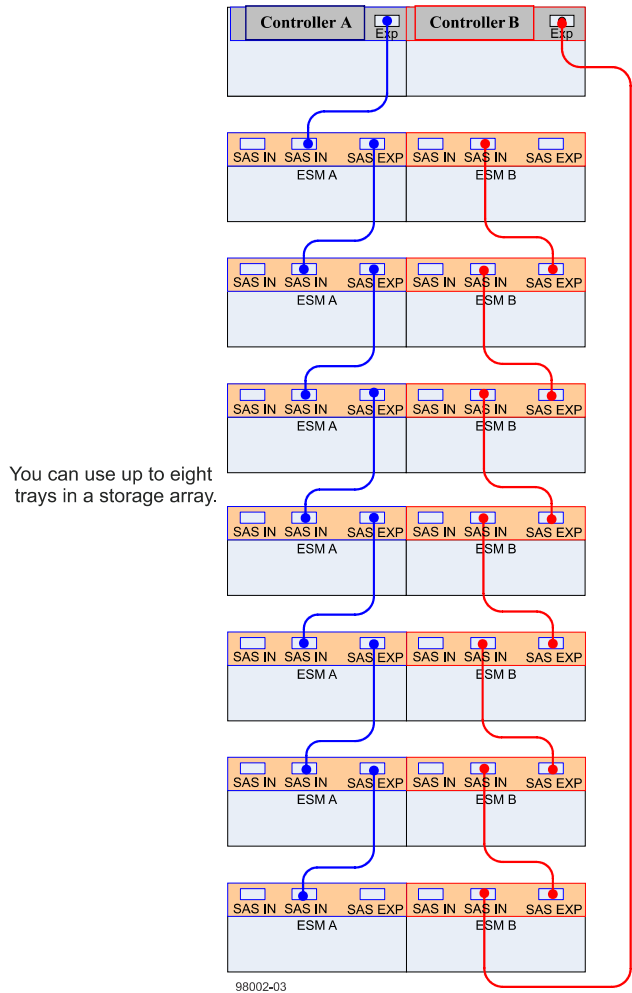


Figure 93. Connecting Cables for Maximum Redundancy and Tray Loss Protection



Procedure –Connecting the DE1600 Drive Trays and the DE5600 Drive Trays

1. Use the following table to determine the number of SAS cables that you need.

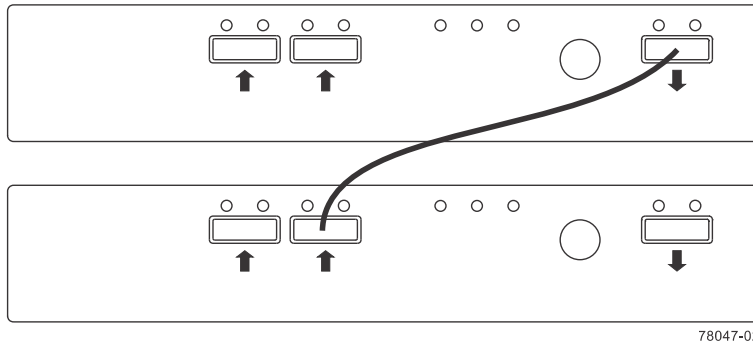
Table 12. Drive Tray Cables

Number of Drive Trays that You Plan to Connect to the Controller-Drive Tray	Number of Cables Required
1	2
2	4
3	6

2. If there is a black, plastic plug in the SAS expansion connector of the controller, remove it.

3. Insert one end of the cable into the SAS expansion connector on the controller in slot A in the controller-drive tray.
4. Insert the other end of the cable into the connector with an up arrow on the ESM in slot A in the drive tray.
5. Are you adding more drive trays?

Figure 94. Connecting a Cable from One ESM to a Second ESM



- **Yes** –Go to step [6](#).
 - **No** –Go to step [9](#).
6. In the ESM in the first drive tray, insert one end of the cable into the connector on the far-right side.
 7. In the ESM in the next drive tray, insert the other end of the cable into either one of the connectors in the left-center of the ESM.
 8. Repeat step [6](#) through step [7](#) for each drive tray that you intend to add to the storage array.
 9. To each end of the cables, attach a label with this information:

- The controller ID (for example, controller A)
- The ESM ID (for example, ESM A)
- The ESM connector (In or Out)
- The drive tray ID

For example, if you are connecting controller A to the In connector on ESM A in drive tray 1, the label on the controller end of the cable will have this information:

```
CtA-Dch1, Dm1-ESM_A (left), In -Controller End
```

The label on the drive tray end of the cable will have this information:

```
Dm1-ESM_A (left), In, CtrlA
```

10. If you are installing the controller-drive tray with two controllers, repeat step [2](#) through step [9](#) for the controller in slot B in the controller-drive tray.

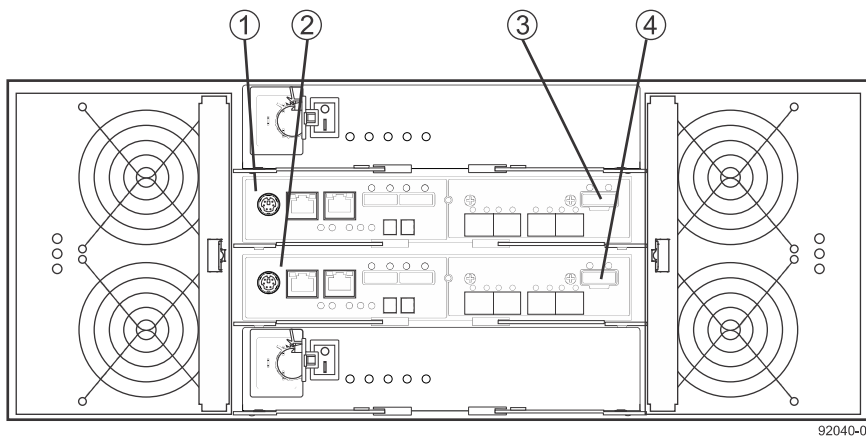
NOTE To connect cables for maximum redundancy, the cables attaching controller B must be connected to the drive trays in the opposite tray order as for controller A. That is, the last drive tray in the chain from controller A must be the first drive tray in the chain from controller B.

Things to Know – E2660 Controller-Drive Tray

NOTE On the E2660 controller-drive tray, each controller has a pair of levers with handles for removing the controller from the controller-drive tray. One of these handles on each controller is located next to a host connector. The close spacing between the handle and the host connector might make it difficult to remove a cable that is attached to the host connector. If this problem occurs, use a flat-blade screwdriver to push in the release component on the cable connector.

- The E2660 controller-drive tray supports the DE6600 drive tray for expansion.
- If all three drive trays are part of the storage array, the maximum number of drive slots in the storage array is 192 drive slots, including up to 60 drive slots in the controller-drive tray.
- If only DE6600 drive trays are part of the storage array, the maximum number of drive slots in the storage array is 182 drive slots, including up to 60 drive slots in the controller-drive tray.
- Exceeding the maximum number of drive slots makes the storage array invalid. The controllers cannot perform operations that modify the configuration, such as creating new volumes.
- Each controller has one dual-ported SAS expansion connector to connect to the drive trays.

Figure 95. Drive Channel Ports on the E2660 Controller-Drive Tray – Rear View



1. Controller A Canister
2. Controller B Canister
3. Controller A SAS Expansion Connector
4. Controller B SAS Expansion Connector

NOTE To maintain data access in the event of the failure of a controller, an ESM, or a drive channel, you must connect a drive tray or a string of drive trays to both drive channels on a redundant path pair.

ATTENTION Potential damage to equipment (Network Telecommunications Equipment (NEBS) Ethernet cable installations only) – The intra-building port(s) (Ethernet maintenance ports) of this equipment is suitable for connection to intra-building or unexposed wiring or cabling only. The intra-building port(s) of this equipment must be metallicly connected to interfaces that connect to the Outside Plant (OSP) or its wiring. These interfaces are designed for use as intra-building interfaces only (Type 2 or Type 4 ports as described in GR-1089-CORE) and require isolation from the exposed OSP cabling. The addition of Primary Protectors is not sufficient protection in order to connect these interfaces metallicly to OSP wiring. The cable shall be shielded Twisted Pair (STP) and must be grounded at both ends to meet the intra-building lightning requirements from section 4.6.9.2 of GR-1089-CORE, Issue#5.

Things to Know – Drive Trays with the E2660 Controller-Drive Tray

Each DE6600 drive tray can contain a maximum of sixty 8.89-cm (3.5-in.) drives housed with five drawers of 12 drives each.

Things to Know – E2660 Drive Tray Cabling Configurations – Duplex System

The figures in this topic show examples of cable configurations from the controller-drive tray to the drive trays. Use these examples as guides to connect cables in your storage array.

You can intermix the DE1600, the DE5600, and DE6600 drive trays with the E2660 controller-drive tray up to a maximum of 192 drive slots in a storage array.

Figure 96. Controller-Drive Tray Above the Drive Tray

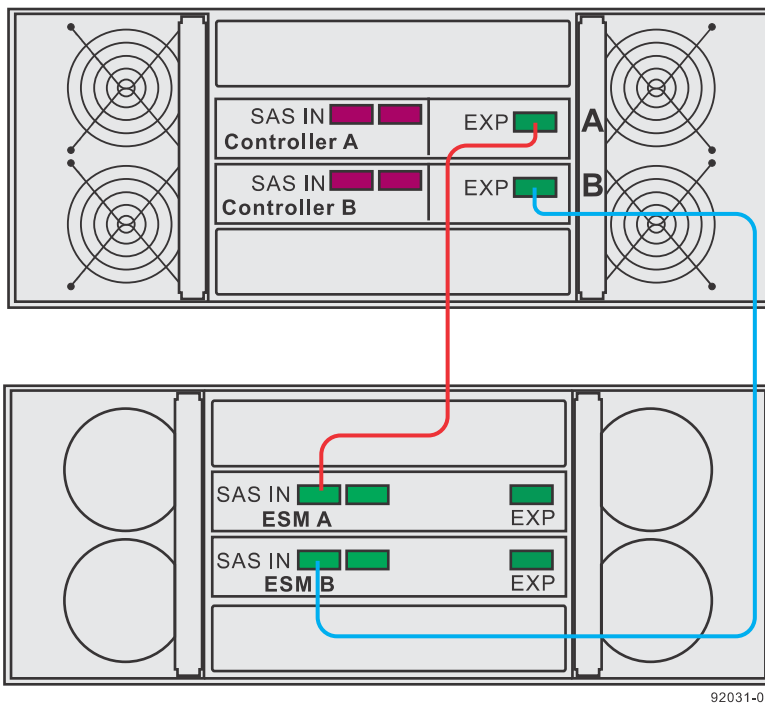
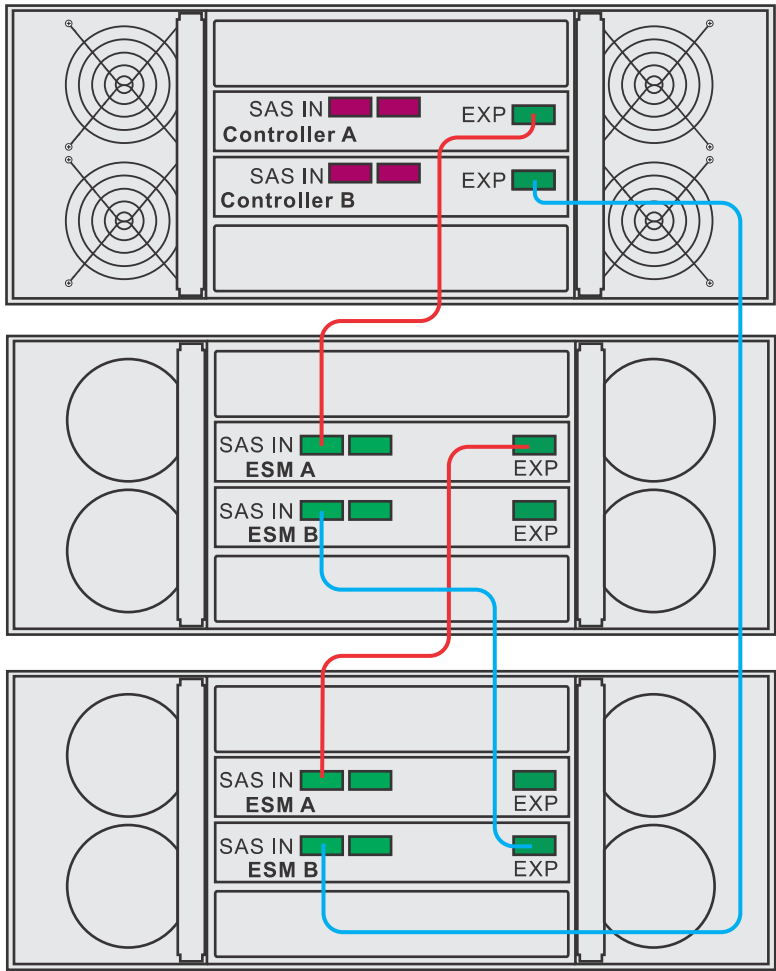


Figure 97. Controller-Drive Tray Between Two Drive Trays



92031-06

Procedure – Connecting the DE6600 Drive Tray

1. Use the following table to determine the number of SAS cables that you need.

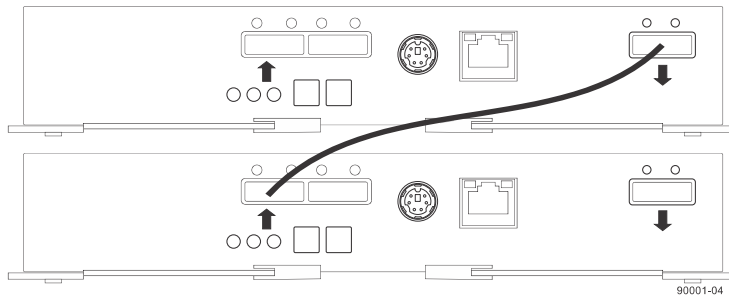
Table 13. Drive Tray Cables

Number of Drive Trays that You Plan to Connect to the Controller-Drive Tray	Number of Cables Required
1	2
2	4

2. If there is a black, plastic plug in the SAS expansion connector of the controller, remove it.
3. Insert one end of the cable into the SAS expansion connector on the controller in slot A.
4. Insert the other end of the cable into the connector with an up arrow on the ESM in slot A in the drive tray.

5. Are you adding more drive trays?

Figure 98. Connecting a Cable from One ESM to a Second ESM



- **Yes** –Go to step [6](#).
 - **No** –Go to step [9](#).
6. In the ESM in the first drive tray, insert one end of the cable into the connector on the far-right side.
 7. In the ESM in the next drive tray, insert the other end of the cable into either one of the connectors in the left-center of the ESM.
 8. Repeat step [6](#) through step [7](#) for each drive tray that you intend to add to the storage array.
 9. To each end of the cables, attach a label with this information:

- The controller ID (for example, controller A)
- The ESM ID (for example, ESM A)
- The ESM connector (In or Out)
- The drive tray ID

For example, if you are connecting controller A to the In connector on ESM A in drive tray 1, the label on the controller end of the cable will have this information:

```
CtA-Dch1, Dm1-ESM_A (left), In -Controller End
```

The label on the drive tray end of the cable will have this information:

```
Dm1-ESM_A (left), In, CtrlA
```

10. If you are installing the controller-drive tray with two controllers, repeat step [2](#) through step [9](#) for the controller in slot B in the controller-drive tray.

IMPORTANT To connect cables for maximum redundancy, the last drive tray in the chain from controller A must be the first drive tray in the chain from controller B.

Step 8 – Connecting the Ethernet Cables

Key Terms

in-band management

A method to manage a storage array in which a storage management station sends commands to the storage array through the host input/output (I/O) connection to the controller. The SMagent must be installed for this method to work correctly.

out-of-band management

A method to manage a storage array in which a storage management station sends commands to the storage array through the Ethernet connections on the controller. This is the recommended management method.

Things to Know – Connecting Ethernet Cables

ATTENTION Risk of security breach – Connect the Ethernet ports on the controller tray to a private network segment behind a firewall. If the Ethernet connection is not protected by a firewall, your storage array might be at risk of being accessed from outside of your network.

- Ethernet port 2 on each controller is reserved for access by Technical Support.
- In limited situations in which the storage management station is connected directly to the controller tray, you must use an Ethernet crossover cable. An Ethernet crossover cable is a special cable that reverses the pin contacts between the two ends of the cable.

Because the controllers support the Auto-MDIX feature, you might not need an Ethernet crossover cable.

Procedure – Connecting Ethernet Cables

Perform these steps to connect Ethernet cables for out-of-band management.

1. Connect one end of an Ethernet cable into the Ethernet port 1 on controller A.
2. Connect the other end to the applicable network connection.
3. Repeat step 1 through step 2 for controller B.

Step 9 – Connecting the Power Cords

The E2600 controller-drive trays, the DE1600 drive tray, the DE5600 drive tray, and the DE6600 drive tray have standard power connections to an AC power source.

IMPORTANT Make sure that you do not turn on the power to the controller-drive tray or the connected drive trays until this documentation instructs you to do so.

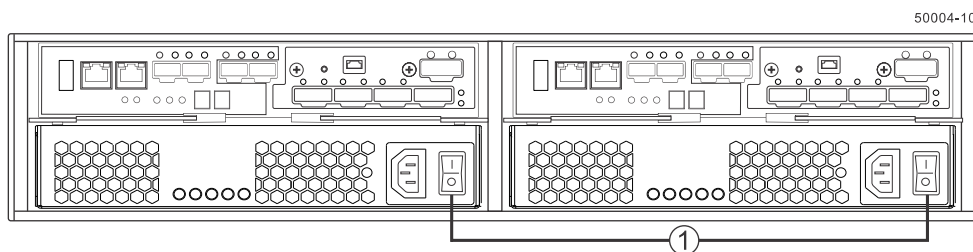
Things to Know – AC Power Cords

- For each AC power connector on the drive tray, make sure that you use a separate power source in the cabinet. Connecting to independent power sources maintains power redundancy.
- To ensure proper cooling, do not operate a drive tray with one of its power supplies removed.
- You can use the power cords shipped with the controller-drive tray with typical outlets used in the destination country, such as a wall receptacle or an uninterruptible power supply (UPS). These power cords, however, are not intended for use in most EIA-compliant cabinets.

Procedure – Connecting AC Power Cords

1. If there is no other equipment in the cabinet that is operational, make sure that the circuit breakers in the cabinet are turned off.
2. Make sure that both of the Power switches on the controller-drive tray are turned off.

Figure 99. Power Switches on the E2612 or E2624 Controller-Drive Tray



1. Power Switches
3. Connect the primary power cords from the cabinet to the external power source.
4. Connect a cabinet interconnect power cord (or power cords specific to your particular cabinet) to the AC power connector on each power canister in the drive tray.
5. If you are installing other drive trays in the cabinet, connect a power cord to each power canister in the drive trays.

Step 10 – Turning on the Power and Checking for Problems in a E2600 Controller-Drive Tray Configuration

After you complete this task, you can install the software and perform basic configuration tasks on your storage array. Continue with either the appropriate Express Guide for your operating system and network protocol or the *Software Installation Reference* if you are installing on an AIX or a Solaris operating system.

Procedure – Turning On the Power to the Storage Array and Checking for Problems in a E2600 Controller-Drive Tray Configuration

NOTE You must turn on the power to all of the connected drive trays before you turn on the power for the controller-drive tray. Performing this action makes sure that the controllers recognize each attached drive tray.

While the power is being applied to the trays, the LEDs on the front and the rear of the trays come on and go off intermittently.

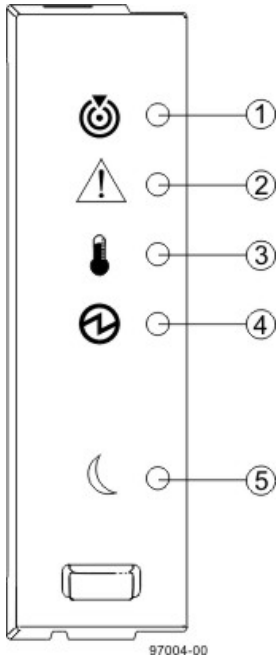
1. If you turned off the circuit breakers in the cabinet in [Procedure – Connecting AC Power Cords](#), turn the circuit breakers on.
2. Turn on both Power switches on each drive tray that is attached to the controller-drive tray. Depending on your configuration, it can take several minutes for each drive tray to complete the power-on process.
3. Check the LEDs on the drive trays to verify that the power was successfully applied to all of the drive trays. Wait 30 seconds after turning on the power to the drive trays before turning on the power to the controller-drive tray.
4. Turn on both Power switches on the rear of the controller-drive tray.
Depending on your configuration, it can take up to ten minutes for the controller-drive tray to complete the power-on process. The controllers reboot several times during the initial startup sequence which causes the fans to ramp up and down and the LEDs to flash on and off.
5. Once the initial startup process has completed, check the LEDs on the front and the rear of the controller-drive tray and the attached drive trays.
6. If you see any amber LEDs, make a note of their location.

Things to Know – LEDs on the E2600 Controller-Drive Tray

The following topics provide details on the LEDs found on the E2600 controller-drive tray.

LEDs on the Left End Cap

Figure 100. LEDs on the Left End Cap



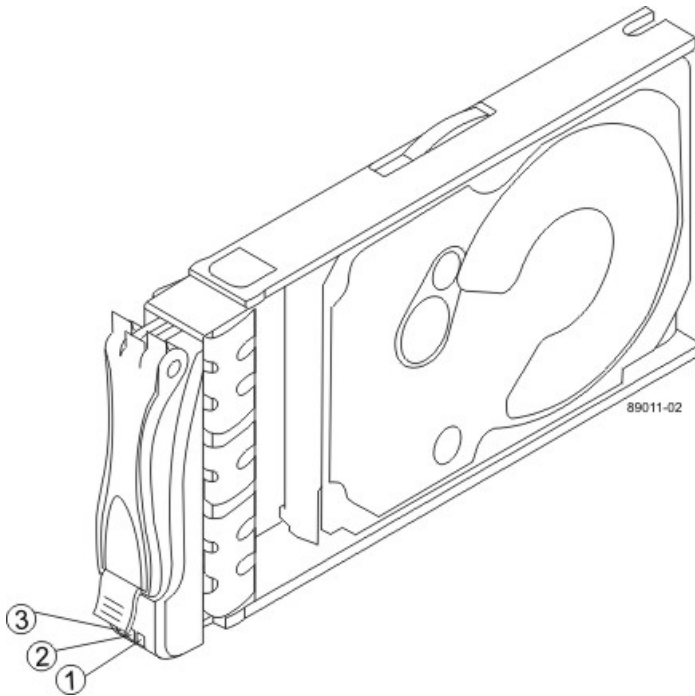
1. Controller-Drive Tray Locate LED
2. Service Action Required LED
3. Controller-Drive Tray Over-Temperature LED
4. Power LED
5. Standby Power LED

Table 14. LEDs on the Left End Cap

Location	LED	Color	On	Off
1	Controller-Drive Tray Locate	White	Identifies a controller-drive tray that you are trying to find.	Normal status.
2	Service Action Required	Amber	A component within the controller-drive tray needs attention.	Normal status.
3	Controller-Drive Tray Over-Temperature	Amber	The temperature of the controller-drive tray has reached an unsafe level.	Normal status.
4	Power	Green	Power is present.	Power is not present.
5	Standby Power	Green	The controller-drive tray is in Standby Power mode.	The controller-drive tray is not in Standby Power mode.

LEDs on the Drive

Figure 101. LEDs on the Drive



1. Drive Power LED
2. Drive Service Action Required LED
3. Drive Service Action Allowed LED

Table 15. LEDs on the Drive

Location	LED	Color	On	Blinking	Off
1	Drive Power	Green	The power is turned on, and the drive is operating normally.	Drive I/O activity is taking place.	The power is turned off.
2	Drive Service Action Required	Amber	An error has occurred.		Normal status.
3	Drive Service Action Allowed	Blue	The drive canister can be removed safely from the controller-drive tray.		The drive canister cannot be removed safely from the controller-drive tray.

Table 16. Drive State Represented by LEDs

Drive State	Drive Power LED (Green)	Drive Service Action Required LED (Amber)
Power is not applied.	Off	Off
Normal operation – The power is turned on, but drive I/O activity is not occurring.	On	Off
Normal operation – Drive I/O activity is occurring.	Blinking	Off

Drive State	Drive Power LED (Green)	Drive Service Action Required LED (Amber)
Service action required – A fault condition exists, and the drive is offline.	On	On

LEDs on the Controller Canister Main Faceplate

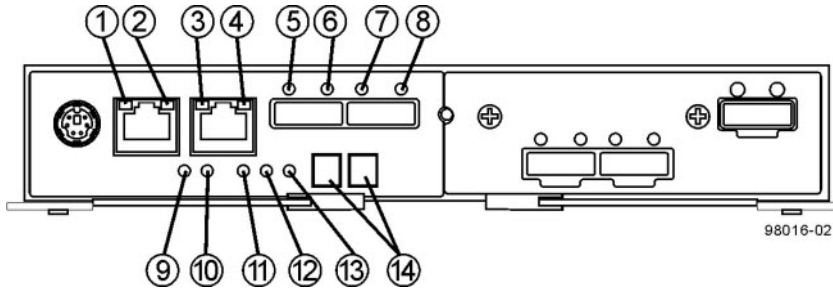


Figure 102. LEDs on the Controller Canister Main Faceplate

1. Ethernet Connector 1 Link Rate LED
2. Ethernet Connector 1 Link Active LED
3. Ethernet Connector 2 Link Rate LED
4. Ethernet Connector 2 Link Active LED
5. Host Link 1 Service Action Required LED
6. Host Link 1 Link Active LED
7. Host Link 2 Service Action Required LED
8. Host Link 2 Link Active LED
9. Battery Service Action Required LED
10. Battery Charging LED
11. Controller Service Action Allowed LED
12. Controller Service Action Required LED
13. Cache Active LED
14. Seven-Segment Tray ID

Table 17. LEDs on the Controller Canister Main Faceplate

Location	LED	Color	On	Off
1	Ethernet Connector 1 Link Rate LED	Green	There is a 100BASE-T rate.	There is a 10BASE-T rate.
2	Ethernet Connector 1 Link Active LED	Green	The link is up (LED blinks when there is activity).	The link is not active.
3	Ethernet Connector 2 Link Rate LED	Green	There is a 100BASE-T rate.	There is a 10BASE-T rate.
4	Ethernet Connector 2 Link Active LED	Green	The link is up (the LED blinks when there is activity).	The link is not active.

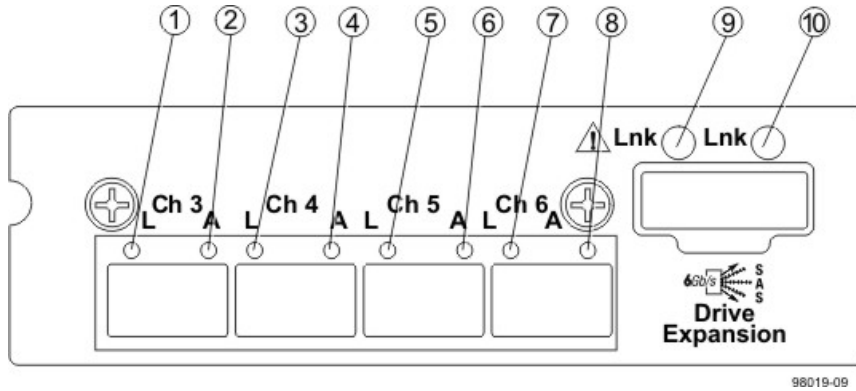
Location	LED	Color	On	Off
5	Host Link 1 Service Action Required LED	Amber	At least one of the four PHYs is working, but another PHY cannot establish the same link to the device connected to the Host IN port connector.	No link error has occurred.
6	Host Link 1 Link Active LED	Green	At least one of the four PHYs in the Host IN port is working and a link exists to the device connected to the IN port connector.	A link error has occurred.
7	Host Link 2 Service Action Required LED	Amber	At least one of the four PHYs is working, but another PHY cannot establish the same link to the device connected to the Host IN port connector.	No link error has occurred.
8	Host Link 2 Link Active LED	Green	At least one of the four PHYs in the Host IN port is working and a link exists to the device connected to the IN port connector.	A link error has occurred.
9	Battery Service Action Required LED	Amber	The battery in the controller canister has failed.	Normal status.
10	Battery Charging LED	Green	The battery is fully charged. The LED blinks when the battery is charging.	The controller canister is operating without a battery or the existing battery has failed.
11	Controller Service Action Allowed LED	Blue	The controller canister can be removed safely from the controller-drive tray.	The controller canister cannot be removed safely from the controller-drive tray.
12	Controller Service Action Required LED	Amber	A fault exists within the controller canister.	Normal status.
13	Cache Active LED	Green	Cache is active.*	Cache is inactive or the controller canister has been removed from the controller-drive tray.

* After an AC power failure, this LED blinks while cache offload is in process.

LEDs on the Controller Canister Host Interface Card Subplates

NOTE The following figure shows an iSCSI host interface card (HIC), but the E2600 controller-drive tray also supports a four-connector FC HIC and a two-connector SAS HIC with comparable LEDs.

Figure 103. LEDs on the Controller Canister Host Interface Card Subplates



1. Host Interface Card Link 3 Up LED
2. Host Interface Card Link 3 Active LED
3. Host Interface Card Link 4 Up LED
4. Host Interface Card Link 4 Active LED
5. Host Interface Card Link 5 Up LED
6. Host Interface Card Link 5 Active LED
7. Host Interface Card Link 6 Up LED
8. Host Interface Card Link 6 Active LED
9. Expansion Fault LED
10. Expansion Active LED

Table 18. LEDs on the Controller Canister Host Interface Card Subplates*

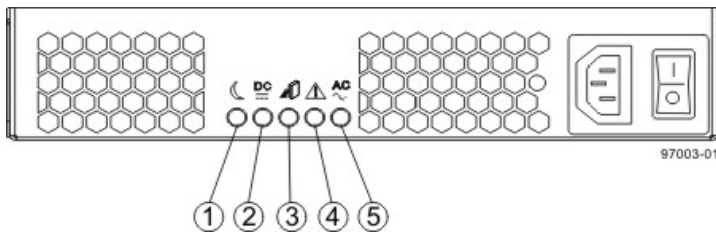
Location	LED	Color	On	Off
1	Host Interface Card Link 3 Up LED	Green	The Ethernet link has auto-negotiated to 1 Gb/s.	The Ethernet link is down or does not auto-negotiate to 1 Gb/s.
2	Host Interface Card Link 3 Active LED	Green	The link is up (LED blinks when there is activity).	The link is not active.
3	Host Interface Card Link 4 Up LED	Green	The Ethernet link has auto-negotiated to 1 Gb/s.	The Ethernet link is down or does not auto-negotiate to 1 Gb/s.
4	Host Interface Card Link 4 Active LED	Green	The link is up (LED blinks when there is activity).	The link is not active.
5	Host Interface Card Link 5 Up LED	Green	The Ethernet link has auto-negotiated to 1 Gb/s.	The Ethernet link is down or does not auto-negotiate to 1 Gb/s.
6	Host Interface Card Link 5 Active LED	Green	The link is up (LED blinks when there is activity).	The link is not active.
7	Host Interface Card Link 6 Up LED	Green	The Ethernet link has auto-negotiated to 1 Gb/s.	The Ethernet link is down or does not auto-negotiate to 1 Gb/s.

Location	LED	Color	On	Off
8	Host Interface Card Link 6 Active LED	Green	The link is up (LED blinks when there is activity).	The link is not active.
9	Expansion Fault LED	Amber	At least one of the four PHY is working, but another PHY cannot establish the same link to the device connected to the Expansion OUT connector.	Normal status.
10	Expansion Active LED	Green	At least one of the four PHYs in the OUT connector is working and a link has been made to the device connected to the Expansion connector.	The link is not active.

* [Figure 103](#) shows the four-port iSCSI host interface card (HIC), which also can be a four-port FC HIC or a two-port SAS HIC.

LEDs on the Power-Fan Canister

Figure 104. LEDs on the Power-Fan Canister



1. Standby Power LED
2. Power-Fan DC Power LED
3. Power-Fan Service Action Allowed LED
4. Power-Fan Service Action Required LED
5. Power-Fan AC Power LED

Table 19. LEDs on the Power-Fan Canister

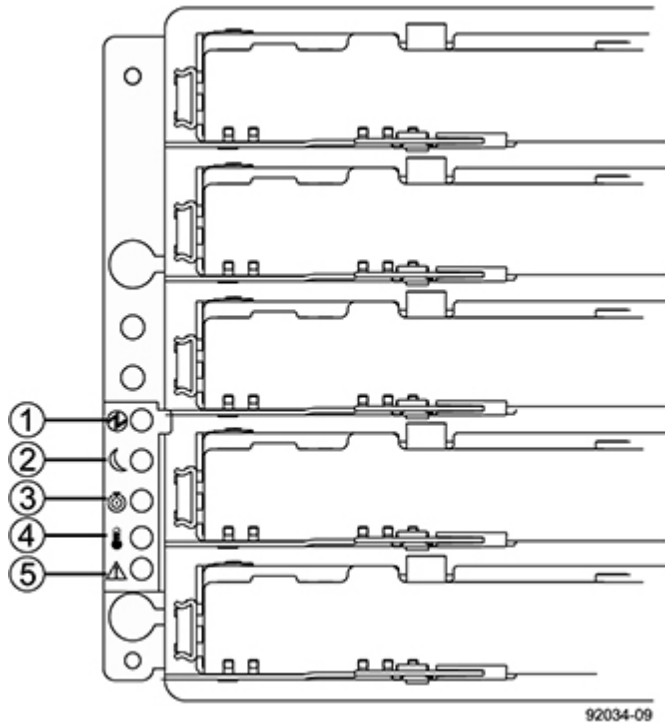
Location	LED	Color	On	Off
1	Standby Power	Green	The controller-drive tray is in Standby mode, and DC power is not available.	The controller-drive tray is not in Standby mode, and DC power is available.
2	Power-Fan DC Power	Green	DC power from the power-fan canister is available.	DC power from the power-fan canister is not available.
3	Power-Fan Service Action Allowed	Blue	The power-fan canister can be removed safely from the controller-drive tray.	The power-fan canister cannot be removed safely from the controller-drive tray.
4	Power-Fan Service Action Required	Amber	A fault exists within the power-fan canister.	Normal status.
5	Power-Fan AC Power	Green	AC power to the power-fan canister is present.	AC power to the power-fan canister is not present.

Things to Know – LEDs on the E2660 Controller-Drive Tray

The following topics provide details on the LEDs found on the E2660 controller-drive tray.

LEDs on the Left Bezel

Figure 105. LEDs on the Left Bezel



1. Power LED
2. Standby Power LED
3. Controller-Drive Tray Locate LED
4. Controller-Drive Tray Over-Temperature LED
5. Service Action Required LED

Table 20. LEDs on the Left Bezel

Location	LED	Color	On	Off
1	Power	Green	Power is present.	Power is not present.
2	Standby Power	Green	The controller-drive tray is in Standby Power mode.	The controller-drive tray is not in Standby Power mode.
3	Controller-Drive Tray Locate	White	Identifies a controller-drive tray that you are trying to find.	Normal status.
4	Controller-Drive Tray Over-Temperature	Amber	The temperature of the controller-drive tray has reached an unsafe level.	Normal status.
5	Service Action Required	Amber	A component within the controller-drive tray needs attention.	Normal status.

LEDs on the Controller Canister Main Faceplate

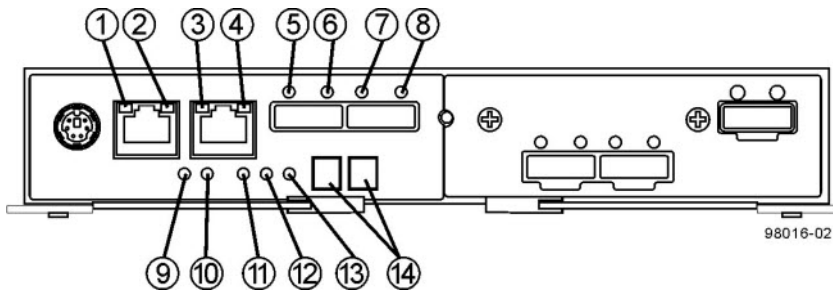


Figure 106. LEDs on the Controller Canister Main Faceplate

1. Ethernet Connector 1 Link Rate LED
2. Ethernet Connector 1 Link Active LED
3. Ethernet Connector 2 Link Rate LED
4. Ethernet Connector 2 Link Active LED
5. Host Link 1 Service Action Required LED
6. Host Link 1 Service Action Allowed LED
7. Host Link 2 Service Action Required LED
8. Host Link 2 Service Action Allowed LED
9. Battery Service Action Required LED
10. Battery Charging LED
11. Controller Service Action Allowed LED
12. Controller Service Action Required LED
13. Cache Active LED
14. Seven-Segment Tray ID

Table 21. LEDs on the Controller Canister Main Faceplate

Location	LED	Color	On	Off
1	Ethernet Connector 1 Link Rate LED	Green	There is a 100BASE-T rate.	There is a 10BASE-T rate.
2	Ethernet Connector 1 Link Active LED	Green	The link is up (LED blinks when there is activity).	The link is not active.
3	Ethernet Connector 2 Link Rate LED	Green	There is a 100BASE-T rate.	There is a 10BASE-T rate.
4	Ethernet Connector 2 Link Active LED	Green	The link is up (the LED blinks when there is activity).	The link is not active.
5	Host Link 1 Service Action Required LED	Amber	At least one of the four PHYs is working, but another PHY cannot establish the same link to the device connected to the Host IN port connector.	No link error has occurred.

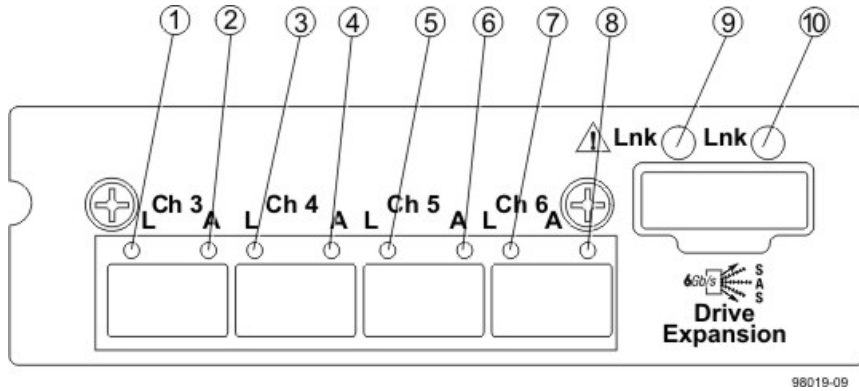
Location	LED	Color	On	Off
6	Host Link 1 Service Action Allowed LED	Green	At least one of the four PHYs in the Host IN port is working and a link exists to the device connected to the IN port connector.	A link error has occurred.
7	Host Link 2 Service Action Required LED	Amber	At least one of the four PHYs is working, but another PHY cannot establish the same link to the device connected to the Host IN port connector.	No link error has occurred.
8	Host Link 2 Service Action Allowed LED	Green	At least one of the four PHYs in the Host IN port is working and a link exists to the device connected to the IN port connector.	A link error has occurred.
9	Battery Service Action Required LED	Amber	The battery in the controller canister has failed.	Normal status.
10	Battery Charging LED	Green	The battery is fully charged. The LED blinks when the battery is charging.	The controller canister is operating without a battery or the existing battery has failed.
11	Controller Service Action Allowed LED	Blue	The controller canister can be removed safely from the controller-drive tray.	The controller canister cannot be removed safely from the controller-drive tray.
12	Controller Service Action Required LED	Amber	A fault exists within the controller canister.	Normal status.
13	Cache Active LED	Green	Cache is active.*	Cache is inactive or the controller canister has been removed from the controller-drive tray.

* After an AC power failure, this LED blinks while cache offload is in process.

LEDs on the Controller Canister Host Interface Card Subplates

The following figure shows an iSCSI host interface card (HIC), but the E2600 controller-drive tray also supports a four-connector FC HIC and a two-connector SAS HIC with comparable LEDs.

Figure 107. LEDs on the Controller Canister Host Interface Card Subplates



1. Host Interface Card Link 3 Up LED
2. Host Interface Card Link 3 Active LED
3. Host Interface Card Link 4 Up LED
4. Host Interface Card Link 4 Active LED
5. Host Interface Card Link 5 Up LED
6. Host Interface Card Link 5 Active LED
7. Host Interface Card Link 6 Up LED
8. Host Interface Card Link 6 Active LED
9. Expansion Fault LED
10. Expansion Active LED

Table 22. LEDs on the Controller Canister Host Interface Card Subplates*

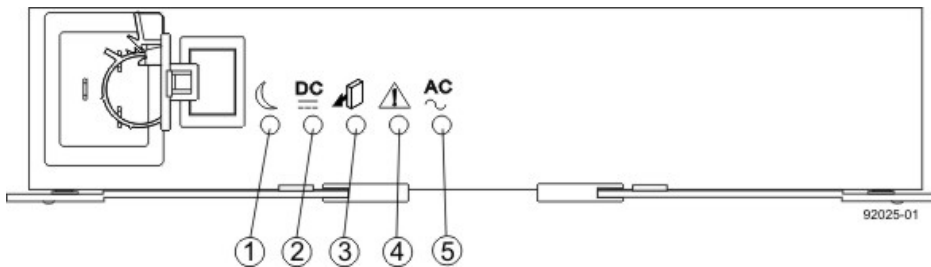
Location	LED	Color	On	Off
1	Host Interface Card Link 3 Up LED	Green	The Ethernet link has auto-negotiated to 1 Gb/s.	The Ethernet link is down or does not auto-negotiate to 1 Gb/s.
2	Host Interface Card Link 3 Active LED	Green	The link is up (LED blinks when there is activity).	The link is not active.
3	Host Interface Card Link 4 Up LED	Green	The Ethernet link has auto-negotiated to 1 Gb/s.	The Ethernet link is down or does not auto-negotiate to 1 Gb/s.
4	Host Interface Card Link 4 Active LED	Green	The link is up (LED blinks when there is activity).	The link is not active.
5	Host Interface Card Link 5 Up LED	Green	The Ethernet link has auto-negotiated to 1 Gb/s.	The Ethernet link is down or does not auto-negotiate to 1 Gb/s.
6	Host Interface Card Link 5 Active LED	Green	The link is up (LED blinks when there is activity).	The link is not active.
7	Host Interface Card Link 6 Up LED	Green	The Ethernet link has auto-negotiated to 1 Gb/s.	The Ethernet link is down or does not auto-negotiate to 1 Gb/s.

Location	LED	Color	On	Off
8	Host Interface Card Link 6 Active LED	Green	The link is up (LED blinks when there is activity).	The link is not active.
9	Expansion Fault LED	Amber	At least one of the four PHY is working, but another PHY cannot establish the same link to the device connected to the Expansion OUT connector.	Normal status.
10	Expansion Active LED	Green	At least one of the four PHYs in the OUT connector is working and a link has been made to the device connected to the Expansion connector.	The link is not active.

*Figure 107 on page 108 shows the four-port iSCSI host interface card (HIC), which can also be a four-port FC HIC or a two-port SAS HIC.

LEDs on the Power-Fan Canister

Figure 108. LEDs on the Power-Fan Canister



1. Standby Power LED
2. Power-Fan DC Power LED
3. Power-Fan Service Action Allowed LED
4. Power-Fan Service Action Required LED
5. Power-Fan AC Power LED





Table 23. LEDs on the Power-Fan Canister







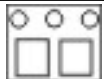

Location	LED	Color	On	Off
1	Standby Power	Green	The controller-drive tray is in Standby mode, and DC power is not available.	The controller-drive tray is not in Standby mode, and DC power is available.
2	Power-Fan DC Power	Green	DC power from the power-fan canister is available.	DC power from the power-fan canister is not available.
3	Power-Fan Service Action Allowed	Blue	The power-fan canister can be removed safely from the controller-drive tray.	The power-fan canister cannot be removed safely from the controller-drive tray.
4	Power-Fan Service Action Required	Amber	A fault exists within the power-fan canister.	Normal status.



Location	LED	Color	On	Off
5	Power-Fan AC Power	Green	AC power to the power-fan canister is present.	AC power to the power-fan canister is not present.

Things to Know – General Behavior of the LEDs on the Controller-Drive Tray

Table 24. LED Symbols and General Behavior

LED	Symbol	Location (Canisters)	Function
Power		Power-fan	<ul style="list-style-type: none"> ■ On – The controller has power. ■ Off – The controller does not have power. <p>NOTE – The controller canisters do not have a Power LED. They receive their power from the power supplies inside the power-fan canisters.</p>
Battery Fault		Battery	<ul style="list-style-type: none"> ■ On – The battery is missing or has failed. ■ Off – The battery is operating normally. ■ Blinking – The battery is charging.
Service Action Allowed		Drive (left LED, no symbol) Power-fan Controller Battery	On – You can remove the canister safely (see Things to Know – Service Action Allowed LEDs).
Service Action Required (Fault)		Drive	<p>On – When the drive tray LED is on, the cable is attached and at least one lane has a link up status, but at least one lane has a link down status.</p> <p>Off – One of the following conditions exists:</p> <ul style="list-style-type: none"> ■ No cable is attached. ■ A cable is attached, and all lanes have a link up status. ■ A cable is attached, and all lanes have a link down status.

LED	Symbol	Location (Canisters)	Function
Service Action Required (Fault)		Controller Power-fan canister	On – The controller or the power-fan canister needs attention. Off – The controller and the power-fan canister are operating normally.
Locate		Front frame	On – Assists in locating the tray.
Host Channel Connection (iSCSI)		Controller	The status of the host channel is indicated: <ul style="list-style-type: none"> ■ “L” LED on – A link is established. ■ “A” LED on – Activity (data transfer) is present.
Cache Active		Controller	The activity of the cache is indicated: <ul style="list-style-type: none"> ■ On – Data is in the cache. ■ Off – No data is in the cache.
Controller-Drive Tray Over-Temperature		Front bezel on the controller-drive tray	On – The temperature of the drive tray has reached an unsafe condition. Off – The temperature of the drive tray is within operational range.
Standby Power		Front bezel on the controller-drive tray	On – The controller tray is in standby mode and the main DC power is off. Off – The controller-drive tray is not in standby mode and the main DC power is on.
Seven-Segment ID Diagnostic Display		Controller	The tray ID or a diagnostic code is indicated. For example, if some of the cache memory dual in-line memory modules (DIMMs) are missing in a controller, error code L8 appears in the diagnostic display (see Things to Know – Lock-Down Codes for the Controller-Drive Tray).
AC power		Power-fan NOTE – The LED is directly above or below the AC power switch and the AC power connector.	Indicates that the power supply is receiving AC power input.

LED	Symbol	Location (Canisters)	Function
DC power		Power-fan NOTE – The LED is directly above or below the DC power switch and the DC power connector.	Indicates that the power supply is receiving DC power input.
Ethernet Speed and Ethernet Activity		Controller	<p>The speed of the Ethernet ports and whether a link has been established are indicated:</p> <ul style="list-style-type: none"> ■ Left LED On – 1-Gb/s speed. ■ Left LED Off – 100BASE-T or 10BASE-T speed. ■ Right LED On – A link is established. ■ Right LED Off – No link exists. ■ Right LED blinking – Activity is occurring.

Things to Know – Service Action Allowed LEDs

Each controller canister, power-fan canister, and battery canister has a Service Action Allowed LED. The Service Action Allowed LED lets you know when you can remove a canister safely.

ATTENTION Possible loss of data access – Never remove a controller canister, a power-fan canister, or a battery canister unless the appropriate Service Action Allowed LED is on.

If a controller canister or a power-fan canister fails and must be replaced, the Service Action Required (Fault) LED on that canister comes on to indicate that service action is required. The Service Action Allowed LED also comes on if it is safe to remove the canister. If data availability dependencies exist or other conditions that dictate a canister should not be removed, the Service Action Allowed LED stays off.

The Service Action Allowed LED automatically comes on or goes off as conditions change. In most cases, the Service Action Allowed LED comes on when the Service Action Required (Fault) LED comes on for a canister.

If the Service Action Required (Fault) LED comes on but the Service Action Allowed LED is off for a particular canister, you might need to service another canister first. Check your storage management software to determine the action that you should take.

When a service action is required for a controller canister, you must place that controller offline before removing it from the enclosure. This prerequisite ensures that the storage array maintains accurate expansion cabling.

Things to Know – LEDs on the DE1600 Drive Tray and the DE5600 Drive Tray

Figure 109. LEDs on the Left End Cap

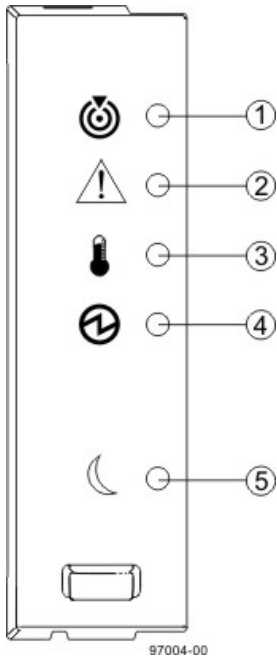


Table 25. LEDs on the Left End Cap

Location	LED	Color	On	Off
1	Drive Tray Locate	White	Identifies a drive tray that you are trying to find.	Normal status.
2	Drive Tray Service Action Required	Amber	A component within the drive tray needs attention.	Normal status.
3	Drive Tray Over-Temperature	Amber	The temperature of the drive tray has reached an unsafe level.	Normal status.
4	Drive Tray Power	Green	Power is present.	Power is not present.
5	Drive Tray Standby Power	Green	The drive tray is in Standby Power mode.	The drive tray is not in Standby Power mode.

Figure 110. LEDs on the Drive

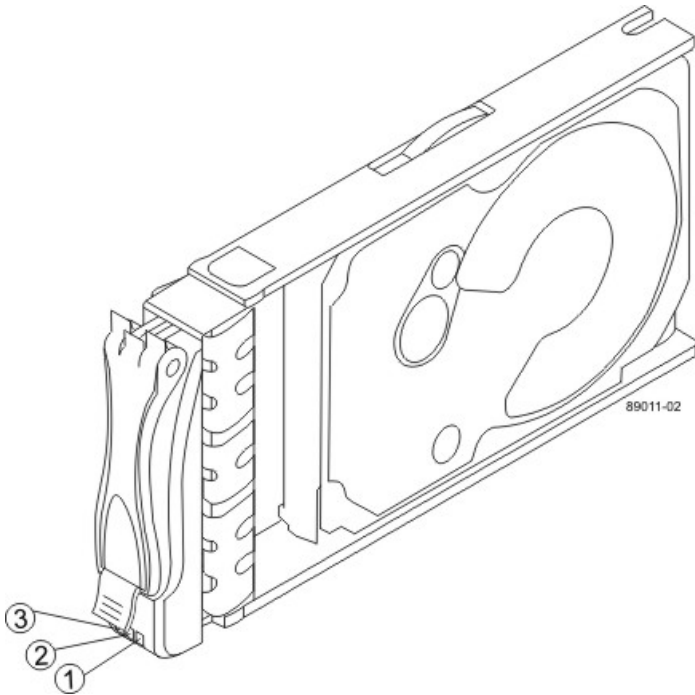


Table 26. LEDs on the Drive

Location	LED	Color	On	Blinking	Off
1	Drive Power	Green	The power is turned on, and the drive is operating normally.	Drive I/O activity is taking place.	The power is turned off.
2	Drive Service Action Required	Amber	An error has occurred.		Normal status.
3	Drive Service Action Allowed	Blue	The drive canister can be removed safely from the drive tray.		The drive canister cannot be removed safely from the drive tray.

Table 27. Drive State Represented by LEDs

Drive State	Drive Power LED (Green)	Drive Service Action Required LED (Amber)
Power is not applied.	Off	Off
Normal operation – The power is turned on, but drive I/O activity is not occurring.	On	Off
Normal operation – Drive I/O activity is occurring.	Blinking	Off
Service action required – A fault condition exists, and the drive is offline.	On	On

Figure 111. LEDs on the ESM Canister

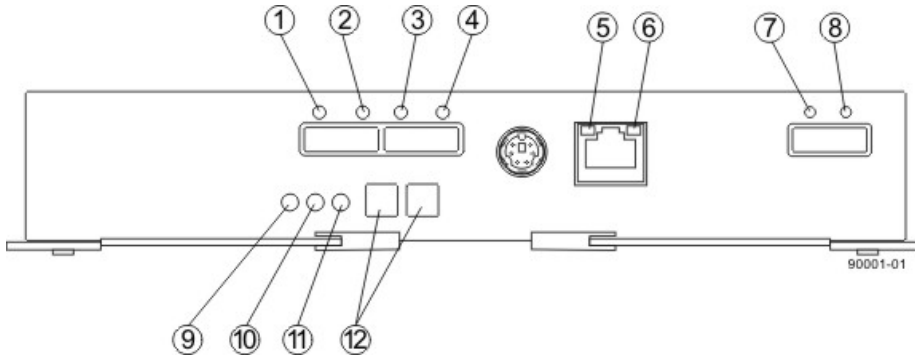


Table 28. LEDs on the ESM Canister

Location	LED	Color	On	Off
1	Host Link 1 Fault	Amber	At least one PHY of the four connectors is working, but another PHY cannot establish the same link to the device connected to the Host IN port connector.	No link error has occurred.
2	Host Link 1 Active	Green	At least one of the four PHYs in the In port is working, and a link exists to the device connected to the Host In connector.	A link error has occurred.
3	Host Link 2 Fault	Amber	At least one PHY of the four connections is working, but another PHY cannot establish the same link to the device connected to the Host In port connector.	No link error has occurred.
4	Host Link 2 Active	Green	At least one of the four PHYs in the IN port is working, and a link exists to the device connected to the Host In connector.	A link error has occurred.
5	Ethernet Link Active	Green	The link is up. (The LED blinks when there is activity.)	The link is not active.
6	Ethernet Link Rate	Green	There is a 100BASE-T rate.	There is a 10BASE-T rate.
7	ESM Expansion Link Fault	Amber	At least one of the four PHYs in the Out port is working, but another PHY cannot establish the same link to the Expansion Out connector.	Normal status.

Location	LED	Color	On	Off
8	ESM Expansion Link Active	Green	At least one of the four PHYs in the Out port is working, and a link exists to the device connected to the Expansion Out connector.	A link error has occurred.
9	ESM Service Action Allowed	Blue	The ESM can be removed safely from the drive tray.	The ESM cannot be removed safely from the drive tray.
10	ESM Service Action Required	Amber	A fault exists within the ESM. (This LED defaults on at power up. This LED turns off after the software has completed its power up self-test sequence.)	Normal status.
11	ESM Power	Green	12V power to the ESM is present.	Power is not present to the ESM.
12	Seven-Segment Tray ID	Green	See note.	Not applicable.

NOTE: For more information about the seven-segment tray IDs, see [Things to Know – Seven-Segment Display for the ESMs on the Drive Trays](#).

Figure 112. LEDs on the AC Power-Fan Canister

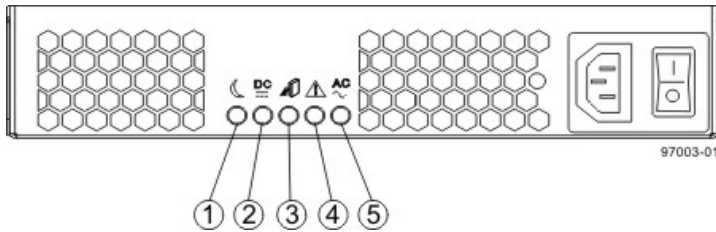


Figure 113. LEDs on the DC Power-Fan Canister

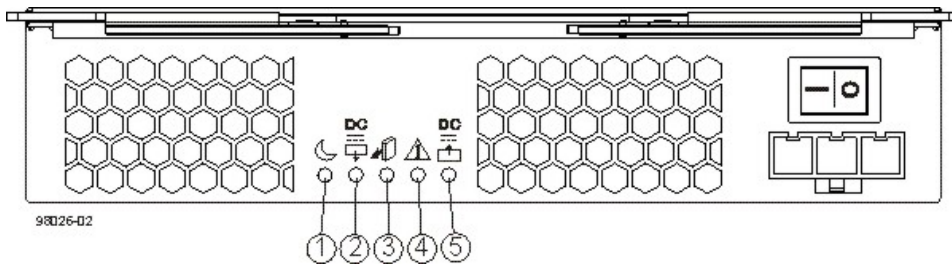


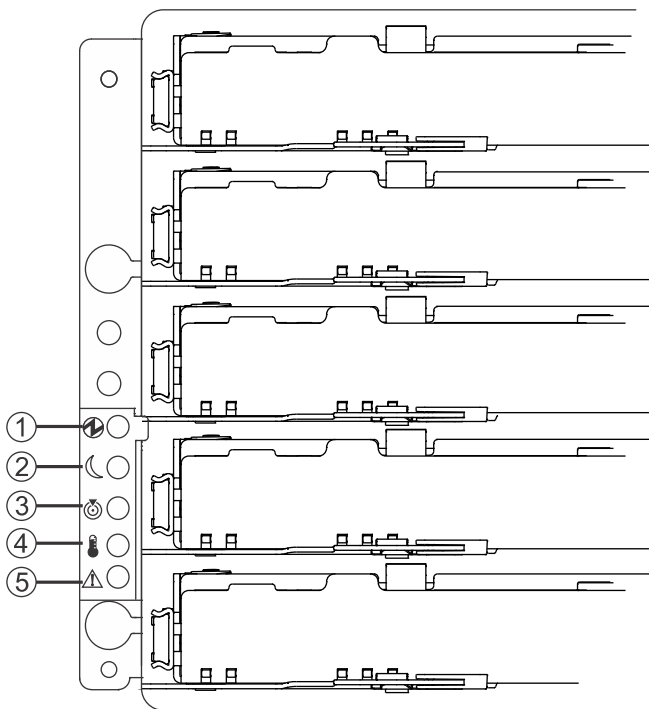
Table 29. LEDs on the Power-Fan Canister

Location	LED	Color	On	Off
1	Standby Power	Green	The drive tray is in Standby mode, and DC power is not available.	The drive tray is not in Standby mode, and DC power is available.
2	Power-Fan DC Power	Green	DC power from the power-fan canister is available.	DC power from the power-fan canister is not available.

Location	LED	Color	On	Off
3	Power-Fan Service Action Allowed	Blue	The power-fan canister can be removed safely from the drive tray.	The power-fan canister cannot be removed safely from the drive tray.
4	Power-Fan Service Action Required	Amber	A fault exists within the power-fan canister.	Normal status.
5	Power-Fan AC Power	Green	AC power to the power-fan canister is present.	AC power to the power-fan canister is not present.

Things to Know – LEDs on the DE6600 Drive Tray

Figure 114. LEDs on the Left Bezel



92034-09

Table 30. LEDs on the Left Bezel

Location	LED	Color	On	Off
1	Drive Tray Power	Green	Power is present.	Power is not present.
2	Drive Tray Standby Power	Green	The drive tray is in Standby Power mode.	The drive tray is not in Standby Power mode.
3	Drive Tray Locate	White	Identifies a drive tray that you are trying to find.	Normal status.
4	Drive Tray Over-Temperature	Amber	The temperature of the drive tray has reached an unsafe level.	Normal status.

Location	LED	Color	On	Off
5	Drive Tray Service Action Required	Amber	A component within the drive tray needs attention.	Normal status.

Figure 115. LEDs on the ESM Canister

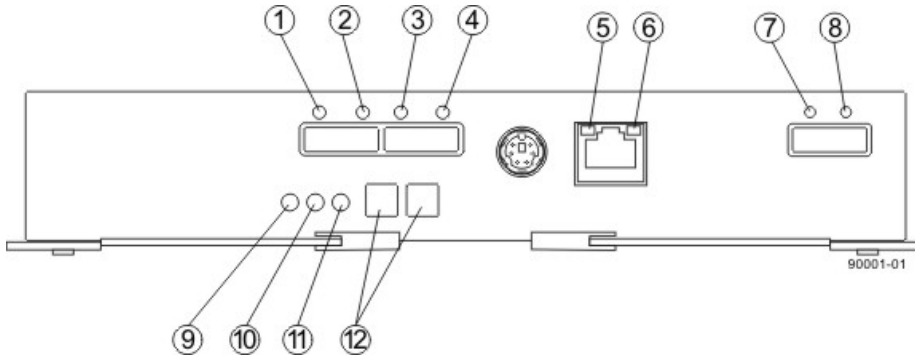


Table 31. LEDs on the ESM Canister

Location	LED	Color	On	Off
1	Host Link 1 Fault	Amber	At least one PHY of the four connectors is working, but another PHY cannot establish the same link to the device connected to the Host IN port connector.	No link error has occurred.
2	Host Link 1 Active	Green	At least one of the four PHYs in the In port is working, and a link exists to the device connected to the Host In connector.	A link error has occurred.
3	Host Link 2 Fault	Amber	At least one PHY of the four connections is working, but another PHY cannot establish the same link to the device connected to the Host In port connector.	No link error has occurred.
4	Host Link 2 Active	Green	At least one of the four PHYs in the IN port is working, and a link exists to the device connected to the Host In connector.	A link error has occurred.
5	Ethernet Link Active	Green	The link is up. (The LED blinks when there is activity.)	The link is not active.
6	Ethernet Link Rate	Green	There is a 100BASE-T rate.	There is a 10BASE-T rate.

Location	LED	Color	On	Off
7	ESM Expansion Link Fault	Amber	At least one of the four PHYs in the Out port is working, but another PHY cannot establish the same link to the Expansion Out connector.	Normal status.
8	ESM Expansion Link Active	Green	At least one of the four PHYs in the Out port is working, and a link exists to the device connected to the Expansion Out connector.	A link error has occurred.
9	ESM Service Action Allowed	Blue	The ESM can be removed safely from the drive tray.	The ESM cannot be removed safely from the drive tray.
10	ESM Service Action Required	Amber	A fault exists within the ESM. (This LED defaults on at power up. This LED turns off after the software has completed its power up self-test sequence.)	Normal status.
11	ESM Power	Green	12V power to the ESM is present.	Power is not present to the ESM.
12	Seven-Segment Tray ID	Green	See note.	Not applicable.

NOTE: For more information about the seven-segment tray IDs, see [Things to Know – Seven-Segment Display for the ESMs on the Drive Trays](#).

Figure 116. LEDs on the AC Power Canister

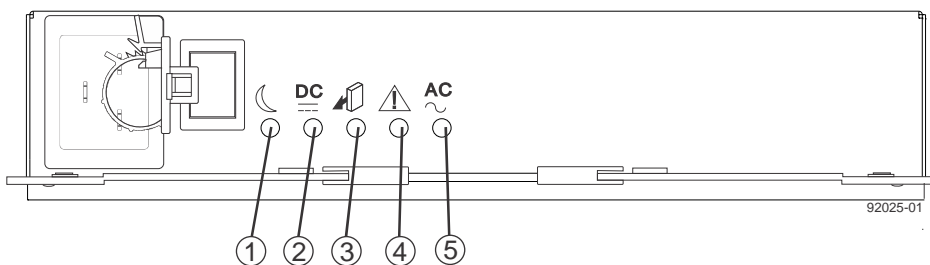


Table 32. LEDs on the AC Power Canister

Location	LED	Color	On	Off
1	Power Standby Power	Green	The drive tray is in Standby mode and DC power is not available.	The drive tray is not in Standby mode.
2	Power DC Power	Green	DC power from the power canister is available.	DC power from the power canister is not available.

Location	LED	Color	On	Off
3	Power Service Action Allowed	Blue	The power canister can be removed safely from the drive tray.	The power canister cannot be removed safely from the drive tray.
4	Power Service Action Required	Amber	A fault exists within the power canister.	Normal status.
5	Power AC Power	Green	AC power to the power canister is present.	AC power to the power canister is not present.

Figure 117. LEDs on the Fan Canister

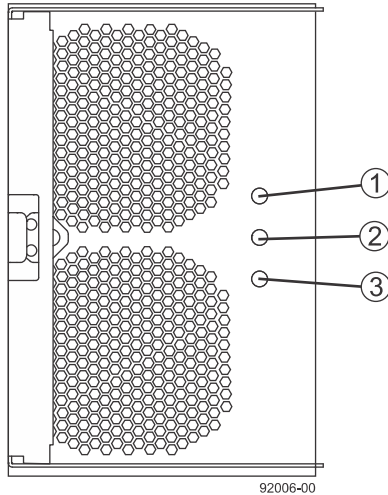


Table 33. LEDs on the Fan Canister

Location	LED	Color	On	Off
1	Fan Power	Green	Power from the fan canister is available.	Power to the fan customer-replaceable unit (CRU) is not available.
2	Fan Service Action Required	Amber	A fault exists within the fan canister.	Normal status.
3	Fan Service Action Allowed	Blue	The fan canister can be removed safely from the drive tray.	The fan canister cannot be removed safely from the drive tray.

LEDs on the DE6600 Drive Drawers

Figure 118. LEDs on the Drawer

92034-03

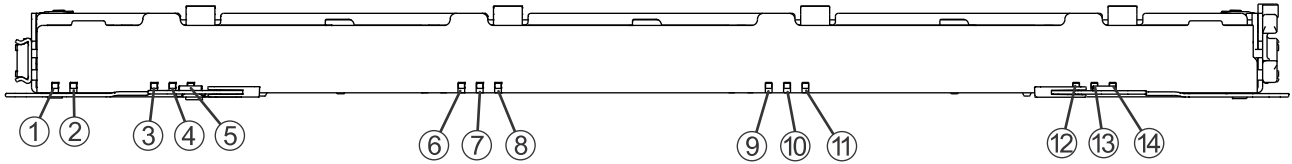
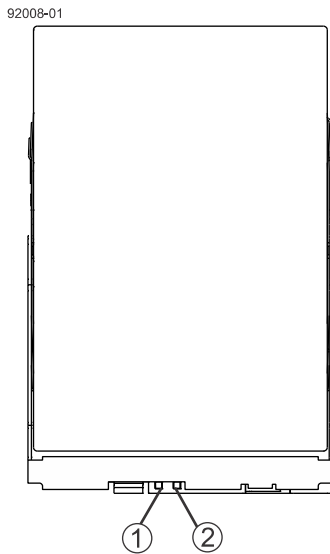


Table 34. LEDs on the Drawer

Location	LED	Color	On	Blinking	Off
1	Drive or Drawer Service Action Allowed	Blue	The drive canister can be removed safely from the drive drawer in the drive tray.		The drive canister cannot be removed safely from the drive drawer in the drive tray.
2	Drive or Drawer Service Action Required	Amber	An error has occurred.		Normal status.
3–14	Drive Activity for drives 1 through 12 in the drive drawer	Green	The power is turned on, and the drive is operating normally.	Drive I/O activity is taking place.	The power is turned off.

Things to Know - LEDs on the DE6600 Drives

Figure 119. LEDs on the DE6600 Drive



1. Drive Service Action Allowed LED
2. Drive Service Action Required LED

Table 35. LEDs on the Drives

Location	LED	Color	On	Blinking	Off
1	Drive Service Action Allowed	Blue	The drive canister can be removed safely from the drive drawer in the drive tray.		The drive canister cannot be removed safely from the drive drawer in the drive tray.
2	Drive Service Action Required	Amber	An error has occurred.		Normal status.

Table 36. Drive State Represented by the LEDs¹










Drive State	Drive Activity LED (Green) ²	Drive Service Action Required LED (Amber)
Power is not applied.	Off	Off
Normal operation – The power is turned on, but drive I/O activity is not occurring.	On	Off
Normal operation – Drive I/O activity is occurring.	Blinking	Off
Service action required – A fault condition exists, and the drive is offline.	On	On


¹To see the drive states represented by the LEDs, you must open the drive drawers one after the other.

²To see the Drive Activity LED view [Figure 118](#).

Things to Know - General Behavior of the LEDs on the Drive Trays

Table 37. LED Symbols and General Behavior

LED	Symbol	Location	General Behavior
Power		Drive tray ESM canister Power-fan canister	On – Power is applied to the drive tray or the canister. Off – Power is not applied to the drive tray or the canister.
Drive Tray Locate		Front bezel on the drive tray	On or blinking – Indicates the drive tray that you are trying to find.
Drive Tray Over-Temperature		Front bezel on the drive tray	On – The temperature of the drive tray has reached an unsafe condition. Off – The temperature of the drive tray is within operational range.
Standby Power		Front bezel on the drive tray	On – The drive tray is in Standby mode, and the main DC power is off. Off – The drive tray is not in Standby mode, and the main DC power is on.
Service Action Allowed		ESM canister Power-fan canister Drive	On – It is safe to remove the ESM canister, the power-fan canister, or the drive. Off – Do not remove the ESM canister, the power-fan canister, or the drive. The drive has an LED but no symbol.
Service Action Required (Fault)		ESM canister Power-fan canister Drive	On – When the drive tray LED is on, a component within the drive tray needs attention. On – The ESM canister, the power-fan canister, or the drive needs attention. Off – The ESM canister, the power-fan canister, and the drive are operating normally. The drive has an LED but no symbol.
AC Power		ESM canister Power-fan canister	On – AC power is present. Off – AC power is not present.
Output DC Power		Power-fan canister	On – Regulated DC output power from the power canister and the fan canister is present. Off – Regulated DC output power from the power-fan canister is not present.
Input DC Power		Power-fan canister	On – Regulated DC input power to the power canister and the fan canister is present. Off – Regulated DC input power to the power-fan canister is not present.

LED	Symbol	Location	General Behavior
Link Service Action Required (Fault)		ESM canister	<p>On – The cable is attached and at least one lane has a link-up status, but one lane has a link-down status.</p> <p>Off – The cable is not attached, the cable is attached and all lanes have a link-up status, or the cable is attached and all lanes have a link-down status.</p>
Link Up	Two LEDs above each expansion connector	ESM canister	<p>On – The cable is attached and at least one lane has a link-up status.</p> <p>Off – The cable is not attached, or the cable is attached and all lanes have a link-down status.</p>

Things to Know –Seven Segment Component Failure Identifications for the E2600 Controller-Drive Tray

Use the Seven Segment display values to identify component.

Table 38. E2600 Controller-Drive Tray Failure Identifications

Component (Code)	Seven-Segment Display Used in this ControllerState		
	Power-on Diagnostics	Suspended	Operational
Processor DIMM (Px +)	yes	yes	no
Cache DIMM (CX +)	yes	yes	no
Host Card (HX +)	yes	yes	yes
Flash Drive (FX +)	no	no	yes
Battery	no	no	no
Category delimiter	The separator between category-detail code pairs is used when more than one category detail code pair exists in the sequence.		
End-of-sequence delimiter	The end-of-sequence delimiter is automatically inserted by the hardware at the end of a code sequence.		
<p>Notes:</p> <ol style="list-style-type: none"> 1. A two-digit code that starts a dynamic display sequence. 2. A two-digit code that follows the category code with more specific information. 3. The plus (+) sign indicates that a two-digit code displays with the Diagnostic LED on. 4. No codes display, and the Diagnostic LED is off. 			

Things to Know – Seven Segment Display Sequence Code Definitions on the E2600 Controller-Drive Tray

During normal operation, the tray ID display on each controller canister shows the controller-drive tray ID. The Diagnostic LED (lower-digit decimal point) comes on when the display is used for diagnostic codes and goes off when the display is used to show the tray ID.

Table 39. Sequence Code Definitions for the E2600 Controller-Drive Tray

Category	Category Code (See Note 1)	Detail Codes (See Note 2)
Startup error	SE+ (See Note 3)	<ul style="list-style-type: none"> ■ 88+ Power-on default ■ dF+ Power-on diagnostic fault ■ Sx Power-on validation error
Operational error	OE+	Lx+ Lock-down codes. (See Things to Know – Lock-Down Codes for the Controller-Drive Tray .)
Operational state	OS+	<ul style="list-style-type: none"> ■ OL+ = Offline. ■ bb+ = Battery backup (operating on batteries). ■ OH + CPU temperature exceeds the warning level ■ CF+ = Component failure. ■ Sd+ = Start of Day (SOD) processing
Component failure	CF+	<ul style="list-style-type: none"> ■ dx+ = Processor or cache DIMM. ■ Cx = Cache DIMM. ■ Px+ = Processor DIMM. ■ Hx+ = Host interface card. ■ Fx+ = Flash drive. ■ bl + Base Controller Card
Diagnostic failure	dE+	Lx+ = Lock-down code.s (See Things to Know – Lock-Down Codes for the Controller-Drive Tray and Things to Know – Seven-Segment Display Use Cases.)
Category delimiter	dash+	The separator between category-detail code pairs is used when more than one category detail code pair exists in the sequence.
End-of-sequence delimiter	blank - (See Note 4)	The end-of-sequence delimiter is automatically inserted by the hardware at the end of a code sequence.
<p>Notes:</p> <p>1 A two-digit code that starts a dynamic display sequence.</p> <p>2 A two-digit code that follows the category code with more specific information.</p> <p>3 The plus (+) sign indicates that a two-digit code displays with the Diagnostic LED on.</p> <p>4 No codes display, and the Diagnostic LED is off.</p>		

Things to Know – Lock-Down Codes for the Controller-Drive Tray

Use the following table to determine the diagnostic lock-down code definitions on the Seven-Segment Display in the controller canister. In general, these diagnostics show only when the controller is in a non-operational state. The controller can be in a non-operational state as a result of a configuration problem (such as mismatched controller types) or as a result of a hardware fault. If the amber Controller Service Action Required LED is on, the non-operational state is the result of a hardware fault.

Table 40. Supported Diagnostic Lock-Down Codes on the Seven-Segment Display

Diagnostic Code	Description
--	The firmware is booting.
L0	The controller types are mismatched, which results in a suspended controller state.
L2	A persistent memory error has occurred, which results in a suspended controller state.
L3	A persistent hardware error has occurred, which results in a suspended controller state.
L4	A persistent data protection error has occurred, which results in a suspended controller state.
L5	An auto-code synchronization (ACS) failure has been detected, which results in a suspended controller state.
L6	An unsupported host interface card has been detected, which results in a suspended controller state.
L7	A sub-model identifier either has not been set or has been mismatched, which results in a suspended controller state.
L8	A memory configuration error has occurred, which results in a suspended controller state.
L9	A link speed mismatch condition has been detected in either the ESM or the power supply, which results in a suspended controller state.
Lb	A host interface card configuration error has been detected, which results in a suspended controller state.
LC	A persistent cache backup configuration error has been detected, which results in a suspended controller state.
Ld	A mixed cache memory DIMMs condition has been detected, which results in a suspended controller state.
LE	Uncertified cache memory DIMM sizes have been detected, which results in a suspended controller state.
LF	The controller has locked down in a suspended state with limited symbol support.
LH	A controller firmware mismatch has been detected, which results in a suspended controller state.
LJ	The controller does not have enough memory to support the configuration, which results in a suspended controller state.
LL	The controller cannot access either midplane SBB EEPROM, which results in a suspended controller state.
Ln	A canister is not valid for a controller, which results in a suspended controller state.

Diagnostic Code	Description
LP	Drive port mapping tables are not detected, which results in a suspended controller state.
Lr	A non field replaceable unit has been replaced, which results in a suspended controller state.
Lt	A configuration data base corruption, which results in a suspended controller state.
LU	The start-of-day (SOD) reboot limit has been exceeded, which results in a suspended controller state.

Things to Know – Seven-Segment Display Use Cases

The following table shows both startup errors and operation errors that can be used to point to a component failure.

Seven-Segment Display Uses Cases with Repeating Sequences

Use Cases	Repeating Sequence
Use Case: Controller power-on	
<ul style="list-style-type: none"> Normal power-on controller insertion Controller inserted while held in reset 	SE+ 88+ blank-
Use Cases	Repeating Sequence
Use Case: Operational states	
<ul style="list-style-type: none"> Normal operation 	xy- (static controller tray ID)
<ul style="list-style-type: none"> Start-of-day (SOD) processing 	OS+ Sd+ blank-
<ul style="list-style-type: none"> The controller is placed in reset while showing the tray ID. 	OS+ OL+ blank-
<ul style="list-style-type: none"> The controller is operating on batteries (cache backup). 	OS+ bb+ blank-
<ul style="list-style-type: none"> The CPU temperature has exceeded the warning level. 	OS+ OH+ blank-
Use Cases	Repeating Sequence
Use Case: Component failure when the controller is operational.	
<ul style="list-style-type: none"> Failed host interface card 	OS+ CF+ HX+ blank-
<ul style="list-style-type: none"> Failed flash drive 	OS+ CF+ Fx+ blank-
Use Cases	Repeating Sequence
Use Case: Power-on diagnostic failure	
<ul style="list-style-type: none"> A component that is not a field replaceable unit failure has been detected. 	SE+ dF+ blank-
<ul style="list-style-type: none"> A processor DIMM failure has been detected. 	SE+ dF+ "--"+ CF+ Px + blank-
<ul style="list-style-type: none"> A cache memory DIMM failure has been detected. 	SE+ dF+ "--"+ CF+ Cx + blank-

Use Cases	Repeating Sequence
<ul style="list-style-type: none"> ■ A processor DIMM or a cache memory DIMM failure has been detected. 	SE+ dF+ "---"+ CF+ dx + blank-
<ul style="list-style-type: none"> ■ A host interface card failure has been detected. 	SE+ dF+ "---"+ CF+ Hx + blank-
<ul style="list-style-type: none"> ■ An incorrect number of cache backup devices have been detected. 	SE+ LC+ "---"+ CF+ Fx + blank-

Use Cases	Repeating Sequence
Use Case: Controller is suspended and there are no other errors to report.	
<ul style="list-style-type: none"> ■ All lockdown conditions 	OH+ Lx+ blank-

Use Cases	Repeating Sequence
Use Case: The controller is suspended because of component errors.	
<ul style="list-style-type: none"> ■ Persistent processor DIMM error correcting code (ECC) errors have been detected. 	OE+ L2+ "---"+ CF+ CX+ blank-
<ul style="list-style-type: none"> ■ Persistent cache DIMM ECC errors have been detected. 	OE+ L2+ "---"+ CF+ CX+ blank-
<ul style="list-style-type: none"> ■ Persistent processor or cache DIMM ECC errors have been detected. 	OE+ L2+ "---"+ CF+ CX+ blank-

Use Cases	Repeating Sequence
Use Case: The controller has been suspended as a result of persistent cache backup configuration errors.	
<ul style="list-style-type: none"> ■ The write-protect switch is set during cache restore. 	OE+ LC+ blank-
<ul style="list-style-type: none"> ■ The memory size changed with dirty data in the flash drives. 	OE+ LC+ dd+ blank-

Use Cases	Repeating Sequence
Use Case: The controller has been suspended as a result of diagnostic errors.	
<ul style="list-style-type: none"> ■ A cache memory diagnostic failure has been detected. 	dE+ L2+ "---"+ CF+ Cx + blank-
<ul style="list-style-type: none"> ■ A base controller diagnostic failure has been detected. 	dE+ L3+ "---"+ CF+ b1 + blank-
<ul style="list-style-type: none"> ■ A base controller IOC diagnostic failure has been detected. 	dE+ L3+ "---"+ CF+ b2 + blank-

Things to Know – Seven-Segment Display for the ESMs on the Drive Trays

During normal operation, the tray ID display on each ESM shows the drive tray ID. The Diagnostic LED (lower-digit decimal point) comes on when the display is used for diagnostic codes and goes off when the display is used to show the tray ID.

If a power-on or reset occurs, the Diagnostic LED, the Heartbeat LED (upper-digit decimal point), and all seven segments of both digits come on. The Diagnostic LED remains on until the drive tray ID appears.

Table 41. Supported Diagnostic Codes on the ESM

Diagnostic Code	Description
--	The firmware is booting.
.8, 8., or 88	This ESM is being held in reset by another ESM.
AA	ESM A firmware is in the process of booting (the diagnostic indicator is not yet set).
bb	ESM B firmware is in the process of booting (the diagnostic indicator is not yet set).
L0	The ESM types are mismatched.
L2	A persistent memory error has occurred.
L3	A persistent hardware error has occurred.
L9	An over-temperature condition has been detected in either the ESM or the power supply.
LL	The midplane SBB VPD EEPROM cannot be accessed.
Ln	The ESM canister is not valid for this drive tray.
LP	Drive port mapping tables are not found.
H0	An ESM Fibre Channel interface failure has occurred.
H1	An SFP transceiver speed mismatch (a 2-Gb/s SFP transceiver is installed when the drive tray is operating at 4 Gb/s) indicates that an SFP transceiver must be replaced. Look for the SFP transceiver with a blinking amber LED.
H2	The ESM configuration is invalid or incomplete, and it operates in a Degraded state.
H3	The maximum number of ESM reboot attempts has been exceeded.
H4	This ESM cannot communicate with the alternate ESM.
H5	A midplane harness failure has been detected in the drive tray.
H6	An ESM firmware failure has been detected.
H8	SFP transceivers are present in currently unsupported ESM slots, either 2A or 2B. Secondary trunking SFP transceiver slots 2A and 2B are not supported. Look for the SFP transceiver with the blinking amber LED, and remove it.
H9	A non-catastrophic hardware failure has occurred. The ESM is operating in a Degraded state.
J0	The ESM canister is incompatible with the drive tray firmware.

Regulatory Compliance Statements

FCC Radio Frequency Interference Statement

This equipment has been tested and found to comply with the limits for a Class A digital device, pursuant to Part 15 of the Federal Communications Commission (FCC) Rules. These limits are designed to provide reasonable protection against harmful interference in a commercial installation. This equipment generates, uses, and can radiate radio frequency energy and, if not installed and used in accordance with the instructions, may cause harmful interference to radio communications. Operation of this equipment in a residential area is likely to cause harmful interference, in which case the user will be required to correct the interference at his/her own expense.

NetApp, Inc. is not responsible for any radio or television interference caused by unauthorized modification of this equipment or the substitution or attachment of connecting cables and equipment other than those specified by NetApp. It is the user's responsibility to correct interference caused by such unauthorized modification, substitution, or attachment.

Laser Products Statement

This equipment uses Small Form-factor Pluggable (SFP) optical transceivers, which are unmodified Class 1 laser products pursuant to 21 CFR, Subchapter J, Section 1040.10. All optical transceivers used with this product are required to be 21 CFR certified Class 1 laser products. For outside the USA, this equipment has been tested and found compliant with Class 1 laser product requirements contained in European Normalization standard EN 60825 1:2007. Class 1 levels of laser radiation are not considered to be hazardous and are considered safe based upon current medical knowledge. This class includes all lasers or laser systems which cannot emit levels of optical radiation above the exposure limits for the eye under any exposure conditions inherent in the design of the laser products.

NetApp, Inc. is not responsible for any damage or injury caused by unauthorized modification of this equipment or the substitution or attachment of connecting cables and equipment other than those specified by NetApp. It is the user's responsibility to correct interference caused by such unauthorized modification, substitution, or attachment.

This Class A digital apparatus meets all requirements of the Canadian Interference-Causing Equipment Regulations.

Cet appareil numérique de la classé A respecte toutes les exigences du Règlement sur le matériel brouilleur du Canada.

この装置は、第一種情報装置（商工業地域において使用されるべき情報装置）で商工業地域での電波障害防止を目的とした情報処理装置等電波障害自主規制協議会（VCCI）基準に適合しております。

従って、住宅地域またはその隣接した地域で使用すると、ラジオ、テレビジョン受信機等に受信障害を与えることがあります。

取扱説明書に従って正しい取り扱いをして下さい。

**警告使用者： 這是甲類的資訊產品，
在居住的環境中使用時，可能會造成
射頻干擾，在這種情況下，使用者會
被要求採取某些適當的對策。**

Japan Electronics And Information Technology Industries Association (JEITA) Power Cable Statement

同梱された電源コードを他の製品に使用しないで下さい。

Translation of JEITA Power Cable notice.:

Do not use power cord with other products.

NetApp社製品には、NetApp社の納入した電源コードのみ使用できます。

Translation of notice:

Use only NetApp supplied power cords with NetApp equipment.

Compliance with the Spanish Royal Decree 106/2008

Este aviso se proporciona de conformidad con, además de otros requisitos, el Real Decreto español 106/2008: El precio de venta al público de las baterías, los acumuladores y las celdas de potencia incluye el coste de la gestión de su desecho.

Translation of Spanish Royal Decree 106/2008: This notice is provided in accordance with the Royal Decree 106/2008 of Spain: The retail price of batteries, accumulators, and power cells includes the cost of the environmental management of their waste.

Compliance with India E-Waste Rule 2011

This product complies with the India E-waste Rule 2011 and does not contain lead, mercury, hexavalent chromium, polybrominated biphenyls or polybrominated di-phenyl ethers above the maximum concentration value of 0.1% by weight in a homogeneous material and does not contain cadmium above the maximum concentration value of 0.01% by weight in homogeneous material except for the exemptions set in Schedule 2 of the Rule.

Trademark information

NetApp, the NetApp logo, Network Appliance, the Network Appliance logo, Akorri, ApplianceWatch, ASUP, AutoSupport, BalancePoint, BalancePoint Predictor, Bycast, Campaign Express, ComplianceClock, Cryptainer, CryptoShred, CyberSnap, Data Center Fitness, Data ONTAP, DataFabric, DataFort, Decru, Decru DataFort, DenseStak, Engenio, Engenio logo, E-Stack, ExpressPod, FAServer, FastStak, FilerView, Flash Accel, Flash Cache, Flash Pool, FlashRay, FlexCache, FlexClone, FlexPod, FlexScale, FlexShare, FlexSuite, FlexVol, FPolicy, GetSuccessful, gFiler, Go further, faster, Imagine Virtually Anything, Lifetime Key Management, LockVault, Manage ONTAP, Mars, MetroCluster, MultiStore, NearStore, NetCache, NOW (NetApp on the Web), Onaro, OnCommand, ONTAPI, OpenKey, PerformanceStak, RAID-DP, ReplicatorX, SANscreen, SANshare, SANtricity, SecureAdmin, SecureShare, Select, Service Builder, Shadow Tape, Simplicity, Simulate ONTAP, SnapCopy, Snap Creator, SnapDirector, SnapDrive, SnapFilter, SnapIntegrator, SnapLock, SnapManager, SnapMigrator, SnapMirror, SnapMover, SnapProtect, SnapRestore, Snapshot, SnapSuite, SnapValidator, SnapVault, StorageGRID, StoreVault, the StoreVault logo, SyncMirror, Tech OnTap, The evolution of storage, Topio, VelocityStak, vFiler, VFM, Virtual File Manager, VPolicy, WAFL, Web Filer, and XBB are trademarks or registered trademarks of NetApp, Inc. in the United States, other countries, or both.

IBM, the IBM logo, and ibm.com are trademarks or registered trademarks of International Business Machines Corporation in the United States, other countries, or both. A complete and current list of other IBM trademarks is available on the web at <http://www.ibm.com/legal/copytrade.shtml>.

Apple is a registered trademark and QuickTime is a trademark of Apple, Inc. in the United States and/or other countries. Microsoft is a registered trademark and Windows Media is a trademark of Microsoft Corporation in the United States and/or other countries. RealAudio, RealNetworks, RealPlayer, RealSystem, RealText, and RealVideo are registered trademarks and RealMedia, RealProxy, and SureStream are trademarks of RealNetworks, Inc. in the United States and/or other countries.

All other brands or products are trademarks or registered trademarks of their respective holders and should be treated as such.

NetApp, Inc. is a licensee of the CompactFlash and CF Logo trademarks.

NetApp, Inc. NetCache is certified RealSystem compatible.

Copyright information

Copyright © 1994–2014 NetApp, Inc. All rights reserved. Printed in the U.S.

No part of this document covered by copyright may be reproduced in any form or by any means— graphic, electronic, or mechanical, including photocopying, recording, taping, or storage in an electronic retrieval system—without prior written permission of the copyright owner.

Software derived from copyrighted NetApp material is subject to the following license and disclaimer:

THIS SOFTWARE IS PROVIDED BY NETAPP "AS IS" AND WITHOUT ANY EXPRESS OR IMPLIED WARRANTIES, INCLUDING, BUT NOT LIMITED TO, THE IMPLIED WARRANTIES OF MERCHANTABILITY AND FITNESS FOR A PARTICULAR PURPOSE, WHICH ARE HEREBY DISCLAIMED. IN NO EVENT SHALL NETAPP BE LIABLE FOR ANY DIRECT, INDIRECT, INCIDENTAL, SPECIAL, EXEMPLARY, OR CONSEQUENTIAL DAMAGES (INCLUDING, BUT NOT LIMITED TO, PROCUREMENT OF SUBSTITUTE GOODS OR SERVICES; LOSS OF USE, DATA, OR PROFITS; OR BUSINESS INTERRUPTION) HOWEVER CAUSED AND ON ANY THEORY OF LIABILITY, WHETHER IN CONTRACT, STRICT LIABILITY, OR TORT (INCLUDING NEGLIGENCE OR OTHERWISE) ARISING IN ANY WAY OUT OF THE USE OF THIS SOFTWARE, EVEN IF ADVISED OF THE POSSIBILITY OF SUCH DAMAGE.

NetApp reserves the right to change any products described herein at any time, and without notice. NetApp assumes no responsibility or liability arising from the use of products described herein, except as expressly agreed to in writing by NetApp. The use or purchase of this product does not convey a license under any patent rights, trademark rights, or any other intellectual property rights of NetApp.

The product described in this manual may be protected by one or more U.S. patents, foreign patents, or pending applications.

RESTRICTED RIGHTS LEGEND: Use, duplication, or disclosure by the government is subject to restrictions as set forth in subparagraph (c)(1)(ii) of the Rights in Technical Data and Computer Software clause at DFARS 252.277-7103 (October 1988) and FAR 52-227-19 (June 1987).

